



RESATEC
SWITZERLAND

+
SWISS
QUALITY
INSIDE



**FEDERN, DÄMPFEN,
SPANNEN, SCHWINGEN.**

**CUSHIONING, ABSORBING,
TENSIONING, OSCILLATING.**

2021

WWW.RESATEC.CH

INHALTSVERZEICHNIS

TABLE OF CONTENTS

WIR SIND RESATEC WE ARE RESATEC	04 – 05
VERTRETUNGEN WELTWEIT REPRESENTATIVES WORLDWIDE	06 – 07
PRODUKTGRUPPEN PRODUCT GROUPS	08 – 09
GUMMIFEDERELEMENTE RUBBER SUSPENSION UNITS	10 – 39
SPANNELEMENTE TENSIONER DEVICES	40 – 53
SCHWINGEELEMENTE OSCILLATING UNITS	54 – 73
SCHWINGUNGSDÄMPFER VIBRATION ABSORBER	74 – 81
MOTORWIPPEN MOTOR BASES	82 – 85
ANWENDUNGEN APPLIFICATIONS	86

WIR SIND RESATEC

WE ARE RESATEC

Gummifederelemente und technische Komponenten – Schweizer Präzision für den Maschinenbau weltweit. Das ist RESATEC!

Es begann vor über 30 Jahren mit einer kleinen Truppe von Spezialisten, welche das Ziel hatten, bestehende Maschinenbaukomponenten in ihren Kerneigenschaften zu optimieren und deren Einsatzbereich entscheidend zu vergrößern.

Durch den Einsatz und die Kombination von neuen Materialien konnten diese Ziele rasch umgesetzt werden. Gummifederelemente von RESATEC kamen auf den Markt und der Grundstein für eine erfolgreiche Firmengeschichte war gelegt!

An dieser Philosophie hat sich nichts geändert. Auch heute sind der Einsatz von neuen Technologien und die Ver-

wendung von innovativen Materialien der Garant für die Entwicklung von RESATEC-Komponenten, die keine Wünsche offen lassen und den Anforderungen im Einsatz ohne Kompromisse gerecht werden. Dass wir dabei grossen Wert auf den Arbeitsplatz **SCHWEIZ** legen und alle Entwicklungen hier planen und unsere Produkte wenn immer möglich in der **SCHWEIZ** produzieren, ist genau so selbstverständlich wie die stetige Weiterbildung unserer Mitarbeiter.

Unsere Ideen und unser Wissen, gepaart mit den innovativsten Materialien und den neuesten Technologien für unsere Ziele einzusetzen – das ist RESATEC!

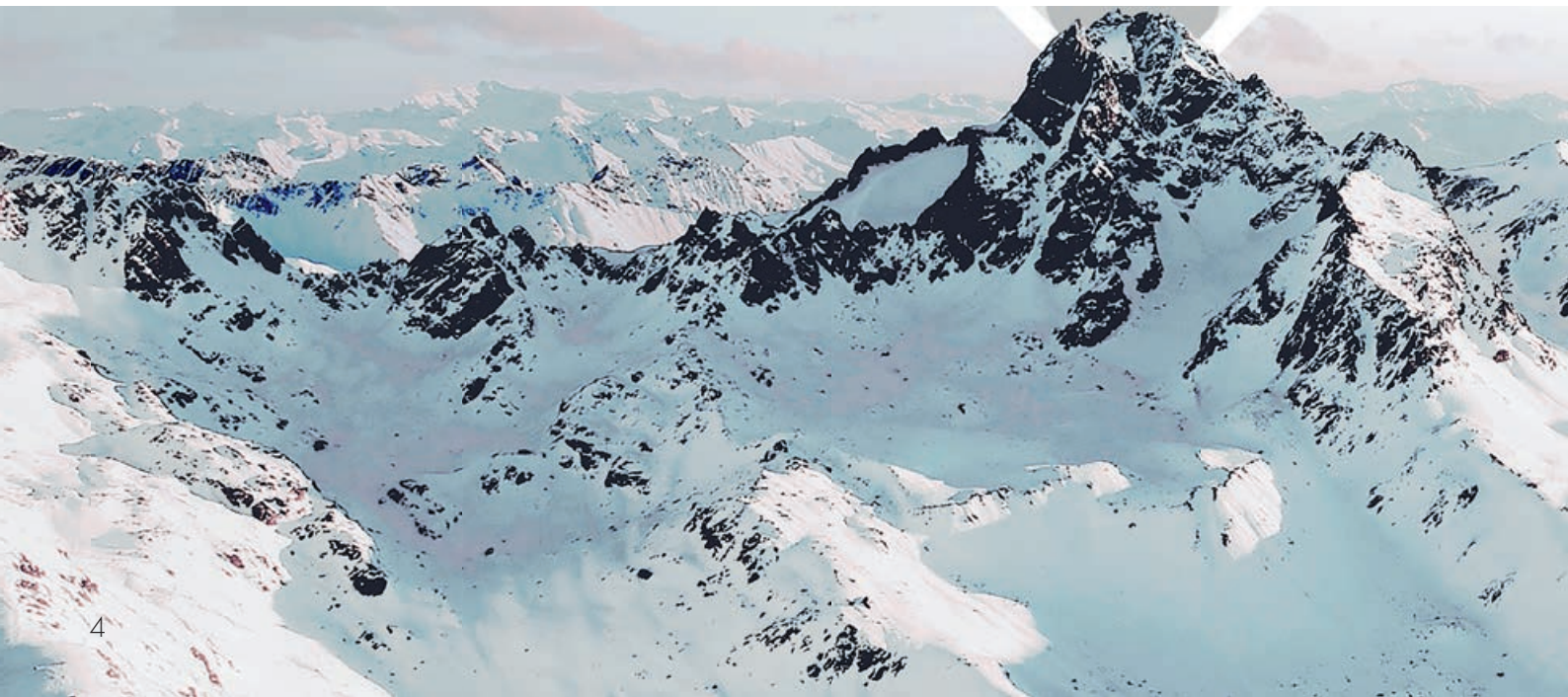

Rubber suspension units and technical components swiss precision for mechanical engineering worldwide. This is RESATEC!

It all began over 30 years ago with a small team of specialists, whose goal was to optimize the core properties of existing machine components and to significantly increase their range of application.

By using and combining new materials, these goals were quickly achieved. Rubber suspension units from RESATEC were launched on the market and the foundation stone for a successful company history was laid!

Nothing has changed in this philosophy. Even today the use of new technologies and innovative materials are the

guarantee for the development of RESATEC components that leave nothing to be desired and meet the requirements in use without compromise. The fact that we attach great importance to the workplace **SWITZERLAND** and that all our developments are engineered here and our products are «**made in SWITZERLAND**» whenever possible, is just as self-evident as the continuous training of our employees.

Using our ideas and our knowledge, combined with the most innovative materials and the latest technologies to achieve our goals – this is RESATEC!



VERTRETUNGEN WELTWEIT REPRESENTATIVES WORLDWIDE



AUSTRALIA

C&R Ventures Australia
16 Kentia Court
AU-6108 Thornlie Perth
T +61 94689630
sales@crventurescoltd.com
www.crventurescoltd.com

Sprockets Australia
216 Whitehall Street
AU-Yarraville VIC 3013
T +61 3 9687 8177
sales@sprocketsoz.com.au
www.sprocketsoz.com.au

AUSTRIA

Bickel & Wolf GmbH
Maschinen-Werkzeugbau
Wienerstrasse 53
AT-3002 Purkersdorf
T +43 (2231) 673 90
office@bickel-wolf.com
www.bickel-wolf.com

CANADA

Kappeli Sales & Service Ltd.
6844 Old Kamploos Road
CA-Vernon - B.C. V1H 1W1
T +1 (250) 549 1124
normbillows@shaw.ca
www.resatec.com

CHINA

Resatec Co. Ltd
No.1 West Wen Er Road
Room 610 Yuanmao Plaza
P.R.C.-310012 Hangzhou
T +86 571 2800 6879
info@resatec.com.cn
www.resatec.com.cn

Best Conveyor Transmission System
Accessories (Quingdao) Co. Ltd
Station Road No.1, Jiazhou Bay
Industrial Park
P.R.C.-Jiaozhou City, Quingdao,
Shandong Province
T +86 (0)532-87273797
ctsbest@hotmail.com

Nanjing TongBiao Technology Co.
Ltd., Zhongshan Science Park Liuhe
Distrikt, R. 504 Building A11 NO.9
Kechuang Street
P.R.C.-211505 Nanjing City Jiangsu
T +86 (0)189- 13257054
gavin.chen001@outlook.com

DANMARK

KJV A/S
Herluf Trolles Vej 3
DK-5220 Odense SO
T +45 70 11 22 44
tc@kjb.dk
www.kjb.dk

FINLAND

Lektar Group/Lektar Oy
P.O. Box 92, Hiekkakiventie 7
FI-00710 Helsinki
T +358 9 413 55 100
info@lektar.com
www.lektar.com

FRANCE

D. O. M.
Distribution Organes Mécaniques
259 Chemin des Clapiers
FR-83220 Le Pradet
T +33 498 016 500
info@dom-france.fr
www.dom-france.fr

Lufra SA
50, Rue Denis Papin
Z.A. Fontgrave
FR-26740 Montboucher sur Jabron
T +33 475468811
commercial@lufra.fr
www.lufra.fr

GERMANY

Flohr Industrietechnik GmbH
Im unteren Tal 1
DE-79761 Waldshut-Tiengen
T +49 (775) 187 310
info@flohr-industrietechnik.de
www.flohr-industrietechnik.de

Heitmann & Bruun GmbH
Reichsbahnstr. 94,
D-22525 Hamburg
T +49 (402) 364 84 80
info@heitmann-und-bruun.de
www.heitmann-und-bruun.de

GREAT BRITAIN

Transmission Developments Co Ltd
Dawkins Road, Hamworthy,
GB-Poole, Dorset, BH15 4HF
T +44 1202 675 555
sales@transdev.co.uk
www.transdev.co.uk

GREECE

Emman. D. Koumakis. S.A.
Sindos Industrial Area of
Thessaloniki
G-57022 Thessaloniki Greece
T +30 (231) 079 67 91
info@koumakis.gr
www.koumakis.gr

INDIA

Milltec Machinery Privat Ltd.
51/A KIAD Industrial Area
IN-560 099 Bommasandra,
Bangalore
T +91 80 27831128
marketing@milltecmachinery.com
www.milltecmachinery.com

ITALY

BEA Ingranaggi SPA
Via Tito Minniti, 158
IT-21044 Cavaria con
Premezzo VA
T +39 0331 214 111
info@beaingranaggi.com
www.beaingranaggi.com

JAPAN

Nabeya Bi-tech Kaisha
Toko Taichi
Seki City
JP-501-3939 Gifu
T +81 (575) 23-1162
info@nbk1560.com
www.nbk1560.com

KOREA

Wontech Co. Ltd.
200, Dalseong2chadong 1-ro
Guji-myeon Dalseong-gun
KR-43013 Taegu-City
T +82 53 557 9111
wontech@wontech.kr
www.wontech.kr

NETHERLAND

Spruit Transmissies B.V.
Ivoorstraat 4
NL-1800 Alkmaar
T +31 72-5412000
verkoop@spruit.nl
www.spruit.nl



NORWAY

FB Kjedor/ Aratron AS
Bjornerudveien 13
NO-1266 Oslo
T +47 231916050
fbkledor@fbkjedor.no
www.fbkjedor.no
firmapost@aratron.no
www.aratron.no

POLAND

MARGO spolka z ograniczona
odpowiedzialnoscia sp.k.
ul.Studzienna 60
PL-87-100 Torun
T +48 (56) 697 20 00
margo@phumargo.pl
www.phumargo.pl

Pivexin Technology Sp .z o.o.
Wyrobskowa 4
PL-47-440 Babice
T +48 32 414 91 53
info@pivexin-tech.pl
www.pivexin-tech.pl

SINGAPORE

Conveyor Transmission Sys PTE Ltd.
Elite Industrial Building 1
32 Kallang Pudding Rd #03-01
Singapore 349313
T +65 674 90282
sales@cts-belting.com
www.cts-belting.com

SOUTH AFRICA

Kwatani (PTY) LTD
Vibrating Equipment Solutions
18 Belgrade Ave.
ZA-1619 Kempton Park
T +27 11 923 9000
sales@kwatani.co.za
service@kwatani.co.za
www.kwatani.co.za

SPAIN

Weda Transmisiones S.L.
C./Ccircunvalacion 45
ES-08210 Barbera del Valles
T +34 93 719 0557
comercial@wedatransmisiones.com
www.wedatransmisiones.com

Transmision S.A.
Calle Segura, 1
ES-28840 Mejorada del Campo
T +34 916 794 491
info@transmision.com
www.transmision.com

Roeirasa
Parque Tecnológico y Logístico
de Vigo
ES-36312 Vigo – Pontevedra
T +34 986 298 800
comercial@roeirasa.es
www.roeirasa.es

SWEDEN

MecMove AB
Speditionsvägen 39
SE-142 50 Skogas
T +46 (0)8 520 140 00
info@mecmove.se
www.mecmove.se

FB Kedjor AB
Sättargatan 4
SE-631 04 Eskilstuna
T. +46 16 15 33 00
order@fbkedjor.se
www.fb-kedjor.se

TAIWAN

Conveyor Transimission Sys Co. Ltd
No 21, Sing-Long Street,
Chang-Sing Village,
Lu-Jhu Township,
Taoyuan Country 338,
Taiwan R.O.C
T +886 3-3223131
sunpwr@singnet.com.sg
www.cts-belting.com

THAILAND

C&R Ventures Co. Ltd.
299/119 Burasiri Moo 10
TH-10540 Samut Bangphil
T +66 879 771 537
roy@crventurescoltd.com
www.crventurescoltd.com

TURKEY

Galata Endüstriyel
Meclis Mah. Ören Sok. No:7
TR-Sancaktepe/STANBUL
T +90 530 313 40 69
galataendustri@gmail.com
www.galataendustri.com

PRODUKT-GRUPPEN PRODUCT GROUPS

GUMMIFEDERELEMENTE

Das RESATEC Gummifederelement ist eine universelle, elastische Lagerung für Maschinenbauteile und vereint eine in zwei Richtungen wirkende Torsionsfeder in einer Komponente.

RUBBER SUSPENSION UNITS

The RESATEC rubber suspension unit is an universal, elastic mounting for mechanical machine parts and combines a torsion spring in two acting directions in one component.

SPANNELEMENTE

Das RESATEC Spannelement ist ein universeller Riemen- und Kettenspanner und die kostensensitive Alternative zu Zug- und Druckfeder.

TENSIONER DEVICES

The RESATEC tensioner device is a universal belt and chain tensioner and the cost-sensitive alternative to tension- and pressure springs

SCHWINGEELEMENTE

Die RESATEC Schwingeelemente sind elastische Lagerungen für Siebmaschinen, Schwingförderrinnen, Kreisschwingsiebe und Plansichter. Die RESATEC-Schwingen werden z. B. für kurbelwellengetriebene Förder-/Sieb-/Sortieranlagen verwendet.

OSCILLATING UNITS

The RESATEC oscillating units are elastic mountings for screening machines, oscillating trough conveyors, circular oscillating screens and gyratory sifters. The RESATEC rockers are used for crankshaft-driven conveying/screening/sorting systems.

SCHWINGUNGSDÄMPFER

Die Produktlinie der RESATEC Schwingungsdämpfer bietet je nach Bauart die Möglichkeit Vibrationen und Stöße zu dämpfen, Schwingungen zu isolieren und ergibt dank der Gummi-Basis eine hervorragende Körperschallisolation.

VIBRATION ABSORBER

The product line of the RESATEC vibration absorbers offers according the building type the possibility to attenuate vibrations and shocks and in case of the rubber material an excellent solid-borne sound insulation.

MOTORWIPPEN

Die RESATEC Motorwippe ist für Friktionsriemenantriebe. Sie lässt sich stufenlos einstellen und garantiert damit eine optimale Riemen Spannung.

MOTOR BASES

The RESATEC motor base is for friction belt drives. It can be adjusted continuously and thus guarantees optimum belt tension.

ANWENDUNGEN

Anwendungsbeispiele verschiedenster Industriezweige.

APPLICATIONS

Application examples of various branches of industry.

1

GUMMIFEDERELEMENTE
RUBBER SUSPENSION UNITS

10 – 39



2

SPANNELEMENTE
TENSIONER DEVICES

40 – 53



3

SCHWINGEELEMENTE
OSCILLATING UNITS

54 – 73



4

SCHWINGUNGSDÄMPFER
VIBRATION ABSORBER

74 – 81



5

MOTORWIPPEN
MOTOR BASES

82 – 85



6

ANWENDUNGEN
APPLICATIONS

86

GUMMIFEDERELEMENTE

RUBBER SUSPENSION UNITS

LTA/LTC/LTS

LTB-A/LTB-C/LTB-S

LTK-A/LTK-C/LTK-S

LTD-A/LTD-C/LTD-S

A

C

S

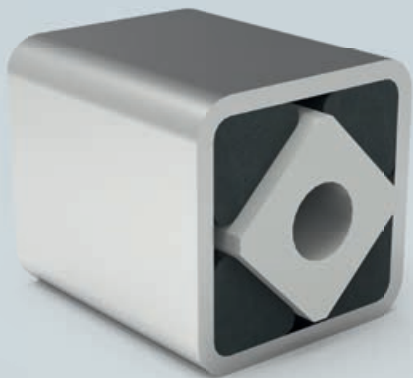

LTC



LTB-A

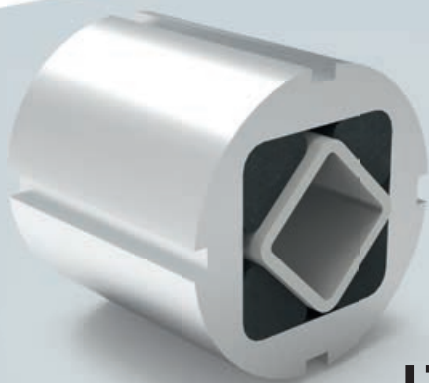

LTK-S

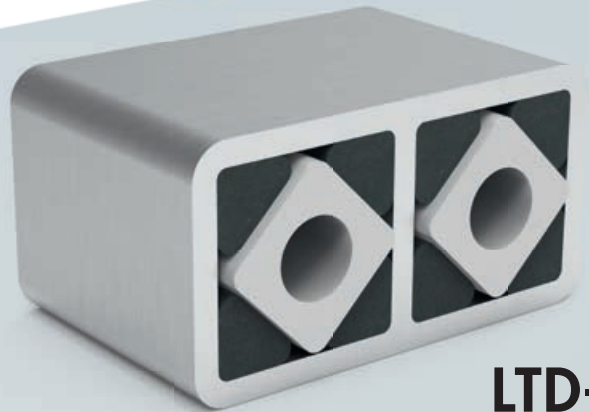

LTD-C

MA



**MONTAGEWINKEL
MOUNTING BRACKET
MA**

CK



MS



**MONTAGEBRIDE
MOUNTING BRACKET
CK/MS**

GUMMIFEDERELEMENT TYP LTA

RUBBER SUSPENSION UNIT TYPE LTA



RESATEC GUMMIFEDERELEMENT TYP LTA:

Das Innenprofil Typ A ermöglicht die Befestigung mit Schrauben. Bis zum Typ LTA 7 sind durchgehende Schrauben der Qualität 8,8 zu verwenden. Ab dem Typ LTA 8 sind im Innenprofil Gewinde vorhanden. Eine weitere einfache Einbaumöglichkeit bietet der RESATEC *Montagewinkel Typ MA*. Aussen wird das Gummifeder-element in ein Futterrohr gesteckt oder mit der RESATEC *Montagebride MS* befestigt. Für wechselseitige Auslenkung über die Element-Nulllage geeignet.

RESATEC RUBBER SUSPENSION UNIT TYPE LTA:

The inner profile type A enables fastening with screws. Up to type LTA 7, through screws of quality 8.8 must be used. From type LTA 8 on, there are threads in the inner profile. Another simple installation option is the RESATEC *mounting bracket type MA*. On the outside, the rubber spring element is inserted into a sleeve tube or fastened with the RESATEC *mounting bracket MS*. Suitable for alternating deflection over the element zero position.



**PASSEND E MONTAGE-
HALTERUNG TYP MS/MA
SEITE 38**

**MATCHING MOUNTING
BRACKET TYPE MS/MA
PAGE 38**

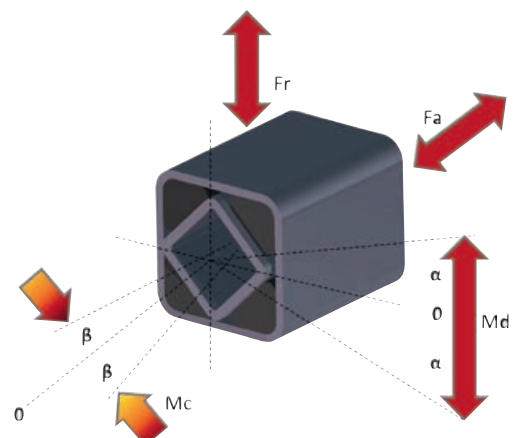
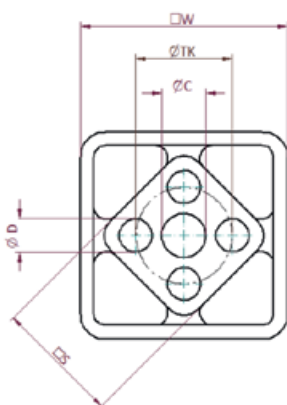

Typ type	Art. Nr. art. no.	□W mm	□S mm	LN mm	L mm	øTk mm	øD mm	øC mm	Anzahl Briden no. of mounting brackets	Gewicht weight kg	Material			
											Aussenrohr outer square tube	Innenprofil core profile	Gummi rubber	
											Typ/type MS			
LTA 4 – 30	560 540 30			30	35						0.1	Stahl S235JR/galvanisch verzinkt steel S235JR/galvanized	Aluminium	Basis auf SBR/Mischung Code C SBR based/mixture code C
LTA 4 – 50	560 540 50	32	18	50	55	12	6	–	1	0.16				
LTA 4 – 80	560 540 80			80	85					0.25				
LTA 5 – 40	560 550 40			40	45				1	0.24				
LTA 5 – 60	560 550 60	45	27	60	65	20	8	–	1	0.36				
LTA 5 – 100	560 551 00			100	105				2	0.6				
LTA 6 – 60	560 560 60			60	70				1	0.59				
LTA 6 – 80	560 560 80	60	38	80	90	25	10	–	1	0.78				
LTA 6 – 120	560 561 20			120	130				2	1.15				
LTA 7 – 80	560 570 80			80	90				1	1.33				
LTA 7 – 100	560 571 00	75	45	100	110	35	12	16.5	2	1.66				
LTA 7 – 150	560 571 50			150	160				3	2.47				
LTA 8 – 120	560 581 20			120	130				2	2.16				
LTA 8 – 200	560 582 00	80	50	200	210	40	M12 × 40	20.5	3	3.66				
LTA 8 – 300	560 583 00			300	310				4	5.54				

Leistungsparameter/performance parameters

Typ type	Art. Nr. art. no.	Drehmoment und max. Erregerfrequenz bei Winkel α Torque and max. excitation frequency at angle α																				
		Radial				Axial																
		MC @ β +/- 1°	Federweg deflection	Belastung load	Federweg deflection	Belastung load	α +/- 4°		α +/- 8°		α +/- 12°		α +/- 16°		α +/- 20°		α +/- 24°		α +/- 28°		α +/- 32°	
Nm	Sr mm	Fr N	Sa mm	Fa N	Nm	min ⁻¹	Nm	min ⁻¹	Nm	min ⁻¹	Nm	min ⁻¹	Nm	min ⁻¹	Nm	min ⁻¹	Nm	min ⁻¹	Nm	min ⁻¹		
LTA 4 – 30	560 540 30	1.51		386		92	1.6	3.37		5.38		7.71		10.4		13.6		17.4		21.8		
LTA 4 – 50	560 540 50	6.68	0.5	644	0.5	153	2.67	1 050	5.64	330	9.07	190	13.1	110	17.9	72	23.6	46	30.4	33	38.4	10
LTA 4 – 80	560 540 80	26.9		1 030		245	4.27	9.01		14.5		20.8		28.3		37.3		47.8		60.2		
LTA 5 – 40	560 550 40	3.99		888		217	4.01	8.22		13.1		19.2		27		37		49.7		65.5		
LTA 5 – 60	560 550 60	12.01	0.5	1 333	0.5	325	6.02	990	12.4	300	19.8	170	29	110	40.9	68	56.2	43	75.6	30	100	10
LTA 5 – 100	560 551 00	49.9		2 221		542	10	20.6		32.9		48.3		67.9		93.2		125		166		
LTA 6 – 60	560 560 60	11.74		1 564		372	11.3	23.7		38.5		56.7		79.6		108		144		188		
LTA 6 – 80	560 560 80	25.4	0.5	2 086	0.5	497	15.1	900	31.7	280	51.4	150	75.9	92	107	57	145	38	194	28	253	10
LTA 6 – 120	560 561 20	78.3		3 130		745	22.6	47.5		77.1		114		160		218		291		380		
LTA 7 – 80	560 570 80	27		2 196		536	22.7	47.1		75.3		110		152		206		272		353		
LTA 7 – 100	560 571 00	52.2	0.5	2 745	0.5	669	28.4	850	58.9	250	94.1	150	137	86	190	57	256	36	338	26	439	10
LTA 7 – 150	560 571 50	135		4 063		991	42.1	87.8		141		206		286		385		508		658		
LTA 8 – 120	560 581 20	81.8		2 828		690	37.2	94.2		171		267		382		517		671		844		
LTA 8 – 200	560 582 00	263	0.5	5 712	0.5	1 393	74.6	840	184	250	329	150	509	85	723	53	971	36	1 254	24	1 570	10
LTA 8 – 300	560 583 00	1 235		8 458		2 063	110.4	272		485		751		1 069		1 440		1 864		2 342		

GUMMIFEDERELEMENT TYP LTC

RUBBER SUSPENSION UNIT TYPE LTC



RESATEC GUMMIFEDERELEMENT TYP LTC:

Das Innenprofil Typ C ermöglicht die Befestigung mit zentraler Schraube. Es sind Schrauben der Qualität 8,8 zu verwenden. Aussen wird das Gummifederelement in ein Futterrohr gesteckt oder mit der RESATEC *Montagebride MS* befestigt. Für wechselseitige Auslenkung bis $\pm 10^\circ$ geeignet.

RESATEC RUBBER SUSPENSION UNIT TYPE LTC:

The inner profile type C enables fastening with central screw. Screws of quality 8.8 must be used. On the outside, the rubber suspension unit is inserted into a sleeve tube or fastened with the RESATEC *mounting bracket MS*. Suitable for alternating deflection up to $\pm 10^\circ$.



PASSENDE MONTAGEHALTERUNG TYP MS SEITE 38

MATCHING MOUNTING
BRACKET TYPE MS
PAGE 38

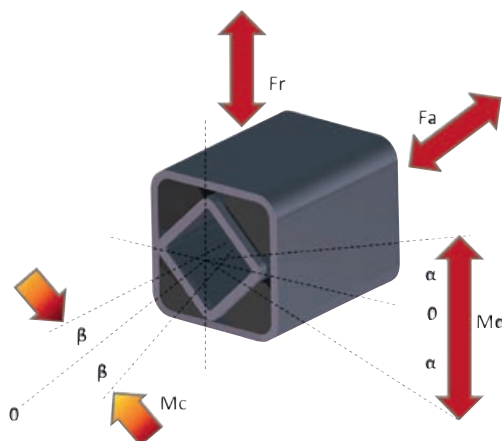
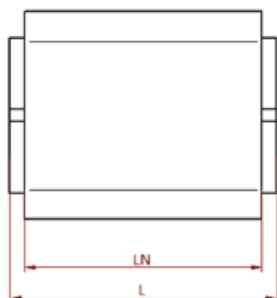
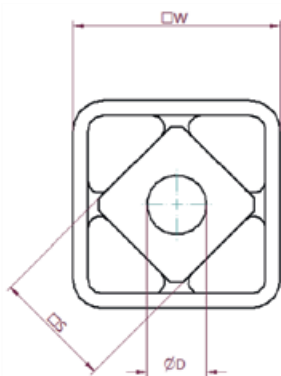

Typ type	Art. Nr. art. no.	□W mm	□S mm	LN mm	L mm	øD +0,5 0 mm.	Anzahl Briden no. of mounting brackets	Gewicht weight kg	Material		
									Aussenrohr outer square tube	Innenprofil core profile	Gummi rubber
LTC 5 – 40	560 150 40			40	45		1	0.24	Stahl S235JR/galvanisch verzinkt steel S235JR/galvanized	Aluminium	Basis auf SBR/Mischung Code C SBR based/mixture code C
LTC 5 – 60	560 150 60	45	27	60	65	6	1	0.36			
LTC 5 – 100	560 151 00			100	105		2	0.59			
LTC 6 – 60	560 160 60			60	70		1	0.59			
LTC 6 – 80	560 160 80	60	38	80	90	8	1	0.77			
LTC 6 – 120	560 161 20			120	130		2	1.14			

Leistungsparameter/performance parameters

Typ type	Art. Nr. art. no.	MC @ β +/- 1° Nm	Radial		Axial		Drehmoment und max. Erregerfrequenz bei Winkel α Torque and max. excitation frequency at angle α															
			Federweg deflection Belastung load	Fr	Federweg deflection Belastung load	Fa	α +/- 4°	α +/- 8°	α +/- 12°	α +/- 16°	α +/- 20°	α +/- 24°	α +/- 28°	α +/- 32°								
			Sr mm	N	Sa mm	N	Nm	min ⁻¹	Nm	min ⁻¹	Nm	min ⁻¹	Nm	min ⁻¹	Nm	min ⁻¹	Nm	min ⁻¹	Nm	min ⁻¹		
LTC 5 – 40	560 150 40	3.99		888		217	4.01		8.22		13.1		19.2		27		37		49.7		65.5	
LTC 5 – 60	560 150 60	12.01	0.5	1333	0.5	325	6.02	990	12.4	300	19.8	170	29	110	40.9	68	56.2	43	75.6	30	100	10
LTC 5 – 100	560 151 00	49.9		2221		542	10		20.6		32.9		48.3		67.9		93.2		125		166	
LTC 6 – 60	560 160 60	11.74		1564		372	11.3		23.7		38.5		56.7		79.6		108		144		188	
LTC 6 – 80	560 160 80	25.4	0.5	2086	0.5	497	15.1	900	31.7	280	51.4	150	75.4	92	107	57	145	38	194	28	253	10
LTC 6 – 120	560 161 20	78.3		3130		745	22.6		47.5		77.1		114		160		218		291		380	

GUMMIFEDERELEMENT TYP LTS

RUBBER SUSPENSION UNIT TYPE LTS

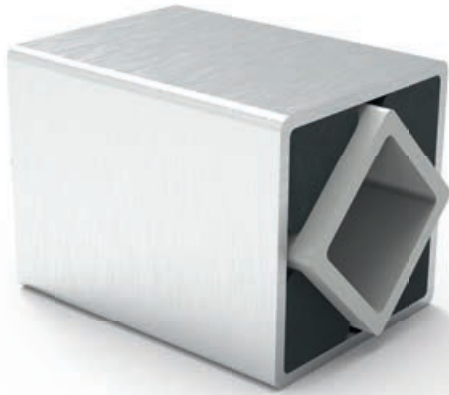

RESATEC GUMMIFEDERELEMENT TYP LTS:

Das Innenprofil Typ S ermöglicht eine Steckverbindung. Die Einstecktiefe des gesteckten Vierkantes soll mindestens dem 1,8-fachen des Materialquerschnittes (Mass S) entsprechen. Als Vierkant soll ein blanker Stahl mit der Toleranz h11 und facettierten Kanten verwendet werden. Aussen wird das Element in ein Futterrohr gesteckt oder mit der RESATEC-Montagebride Typ MS befestigt. Eine wechselseitige Auslenkung über die Element-Nulllage ist nicht möglich.

RESATEC RUBBER SUSPENSION UNIT TYPE LTS:

The inner profile type S enables a plug-in connection. The insertion depth of the inserted square should be at least 1.8 times the material cross-section (dimension S). The square should be made of bright steel with tolerance h11 and faceted edges.

On the outside, the element is inserted into a sleeve tube or fastened with the RESATEC *mounting bracket type MS*. An alternating deflection over the element zero position is not possible.



PASSENDEN MONTAGEHALTERUNG TYP MS
SEITE 38

MATCHING MOUNTING BRACKET TYPE MS
PAGE 38

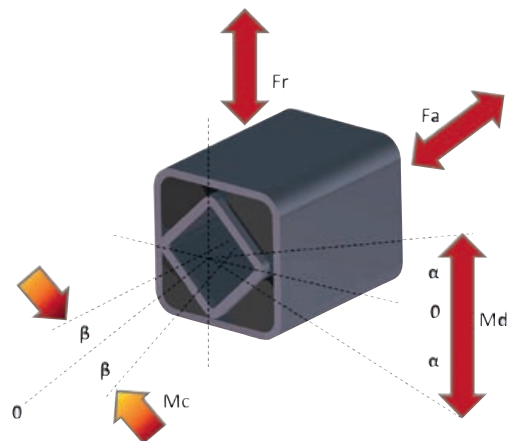
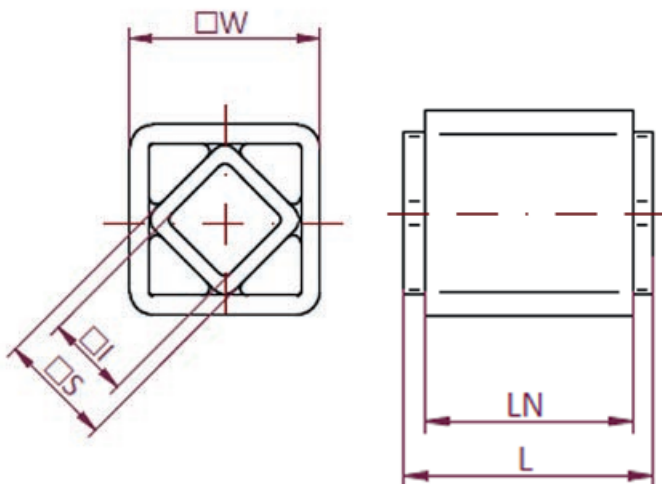

Typ type	Art. Nr. art. no.	□W	□S	LN	L	□I	Anzahl Briden no. of mounting brackets	Gewicht weight	Material		
									Aussenrohr outer square tube	Innenprofil core profile	Gummi rubber
		mm	mm	mm	mm	mm	Typ/type MS	kg			
LTS 2 – 20	560 420 20			20	25			0.03	Stahl S235JR/galvanisch verzinkt steel S235JR/galvanized	Stahl S235JR/galvanisch verzinkt steel S235JR/galvanized	Basis auf SBR/Mischung Code C SBR based/mixture code C
LTS 2 – 30	560 420 30	20	11	30	35	8	1	0.044			
LTS 2 – 50	560 420 50			50	55			0.071			
LTS 3 – 25	560 430 25			25	30			0.08			
LTS 3 – 40	560 430 40	27	15	40	45	11	1	0.12			
LTS 3 – 60	560 430 60			60	65			0.18			
LTS 4 – 30	560 440 30			30	35			0.11			
LTS 4 – 50	560 440 50	32	18	50	55	12	1	0.18			
LTS 4 – 80	560 440 80			80	85			0.28			
LTS 5 – 40	560 450 40			40	45		1	0.27			
LTS 5 – 60	560 450 60	45	27	60	65	22	1	0.4			
LTS 5 – 100	560 451 00			100	105		2	0.65			
LTS 6 – 60	560 460 60			60	70		1	0.66			
LTS 6 – 80	560 460 80	60	38	80	90	30	1	0.86			
LTS 6 – 120	560 461 20			120	130		2	1.27			
LTS 7 – 80	560 470 80			80	90		1	1.57			
LTS 7 – 100	560 471 00	75	45	100	110	35	2	1.95			
LTS 7 – 150	560 471 50			150	160		3	2.9			
LTS 8 – 120	560 481 20			120	130		2	2.58			
LTS 8 – 200	560 482 00	80	50	200	210	40	3	4.25			
LTS 8 – 300	560 483 00			300	310		4	6.34			

Leistungsparameter/performance parameters

Typ type	Art. Nr. art. no.	MC @ β +/- 1°	Radial		Axial		Drehmoment und max. Erregerfrequenz bei Winkel α Torque and max. excitation frequency at angle α															
			Federweg deflection	Belastung load	Federweg deflection	Belastung load	α +/- 4°		α +/- 8°		α +/- 12°		α +/- 16°		α +/- 20°		α +/- 24°		α +/- 28°		α +/- 32°	
			Nm	Sr mm	Fr N	Sa mm	Fa N	Nm	min ⁻¹	Nm	min ⁻¹	Nm	min ⁻¹	Nm	min ⁻¹	Nm	min ⁻¹	Nm	min ⁻¹	Nm	min ⁻¹	Nm
LTS 2 – 20	560 420 20	0.38		246		63	0.33	0.63		0.92		1.26		1.68		2.22		2.92		3.81		
LTS 2 – 30	560 420 30	1.06	0.25	377	0.25	97	0.5	1150	0.97	350	1.48	190	2.11	130	2.95	75	4.05	46	5.51	33	7.4	10
LTS 2 – 50	560 420 50	5.4		624		160	0.83	1.59		2.4		3.38		4.63		6.28		8.43		11.2		
LTS 3 – 25	560 430 25	0.6		214		69	0.6	1.4		2.2		3.2		4.4		5.7		7.3		9.1		
LTS 3 – 40	560 430 40	2	0.25	343	0.25	111	1	1100	2.2	330	3.5	190	5.1	120	7	72	9.2	46	11.7	33	14.7	10
LTS 3 – 60	560 430 60	5.47		513		166	1.5	3.2		5.2		7.5		10.1		13.1		16.5		20.3		
LTS 4 – 30	560 440 30	1.51		386		92	1.6	3.37		5.38		7.71		10.4		13.6		17.4		21.8		
LTS 4 – 50	560 440 50	6.68	0.5	644	0.5	153	2.67	1050	5.64	330	9.07	190	13.1	110	17.9	72	23.6	46	30.4	33	38.4	10
LTS 4 – 80	560 440 80	26.9		1030		245	4.27	9.01		14.5		20.8		28.3		37.3		47.8		60.2		
LTS 5 – 40	560 450 40	3.99		888		217	4.01	8.22		13.1		19.2		27		37		49.7		65.5		
LTS 5 – 60	560 450 60	12.01	0.5	1333	0.5	325	6.02	990	12.4	300	19.8	170	29	110	40.9	68	56.2	43	75.6	30	100	10
LTS 5 – 100	560 451 00	49.9		2221		542	10	20.6		32.9		48.3		67.9		93.2		125		166		
LTS 6 – 60	560 460 60	11.74		1564		372	11.3	23.7		38.5		56.7		79.6		108		144		188		
LTS 6 – 80	560 460 80	25.4	0.5	2086	0.5	497	15.1	900	31.7	280	51.4	150	75.9	92	107	57	145	38	194	28	253	10
LTS 6 – 120	560 461 20	78.3		3130		745	22.6	47.5		77.1		114		160		218		291		380		
LTS 7 – 80	560 470 80	27		2196		536	22.7	47.1		75.3		110		152		206		272		353		
LTS 7 – 100	560 471 00	52.2	0.5	2745	0.5	669	28.4	850	58.9	250	94.1	150	137	86	190	57	256	36	338	26	439	10
LTS 7 – 150	560 471 50	135		4063		991	42.1	87.8		141		206		286		385		508		658		
LTS 8 – 120	560 481 20	81.8		2828		690	37.2	94.2		171		267		382		517		671		844		
LTS 8 – 200	560 482 00	263	0.5	5712	0.5	1393	74.6	840	184	250	329	150	509	85	723	53	971	36	1254	24	1540	10
LTS 8 – 300	560 483 00	1235		8458		2063	110.4	272		485		751		1069		1440		1864		2342		

GUMMIFEDERELEMENT TYP LTB-A

RUBBER SUSPENSION UNIT TYPE LTB-A

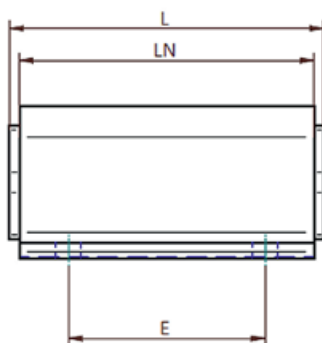
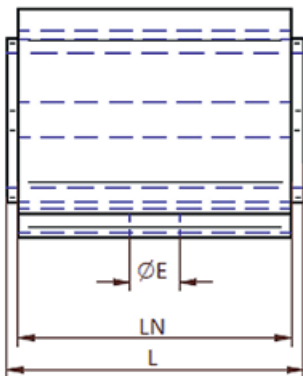
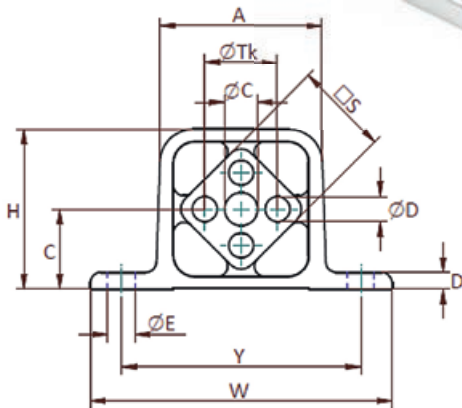

Grösse/size 5/6/7

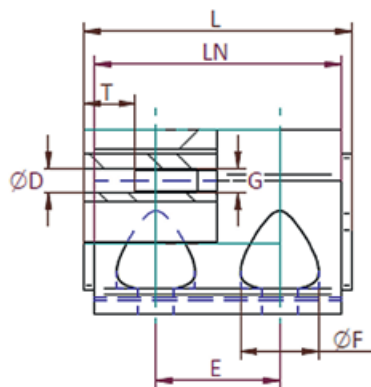

Grösse/size 8

RESATEC GUMMIFEDERELEMENT TYP LTB-A:

Das Innenprofil Typ A ermöglicht die Befestigung mit Schrauben. Bis zum Typ LTB-A 7 sind durchgehende Schrauben der Qualität 8,8 zu verwenden. Ab dem Typ LTB-A 8 sind im Innenprofil Gewinde vorhanden. Eine weitere einfache Einbaumöglichkeit bis zur Grösse LTB-A 8 bietet der RESATEC *Montagewinkel Typ MA*. Das Aussengehäuse kann durch die Befestigungslöcher in der Flanschpartie direkt mit Schrauben der Qualität 8,8 befestigt werden. Für wechselseitige Auslenkung über die Element-Nulllage geeignet.

RESATEC RUBBER SUSPENSION UNIT TYPE LTB-A:

The inner profile type A allows fastening with screws. Up to type LTB-A 7, screws of quality 8.8 must be used. From type LTB-A 8, there are threads in the inner profile. Another simple installation option up to size LTB-A 8 is offered by the RESATEC *mounting bracket type MA*. The outer housing can be fastened directly with quality 8.8 screws through the fastening holes in the flange section. Suitable for alternating deflection over the element zero position.

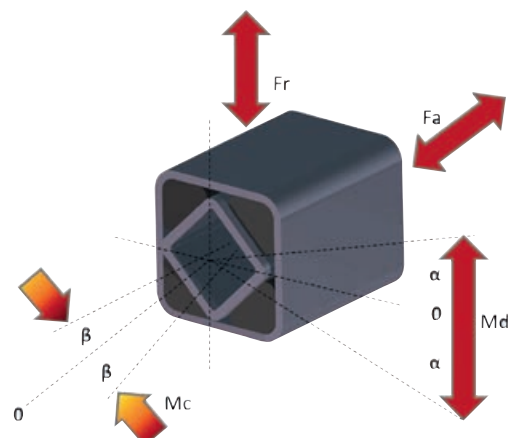

Abmasse/Material/dimensions/material

Typ type	Art. Nr. art. no.	A	C	øC	D	øD	E	øE	øF	G	H	L	LN	□S	øTk	T	W	Y	Gewicht weight				
		mm	mm	mm	mm	mm	mm	mm	mm	mm	mm	mm	mm	mm	mm	mm	mm	mm	mm	kg			
LTB-A 5 – 40	561 550 40						–					45	40			Durchgangsbohrung/through bore-hole				0.21			
LTB-A 5 – 60	561 550 60	49	25.5	–	5	8	–	11	–	–	50	65	60	27	20			105	80		0.32		
LTB-A 5 – 100	561 551 00						60					105	100									0.51	
LTB-A 6 – 60	561 560 60						–					70	60									0.59	
LTB-A 6 – 80	561 560 80	66	34	–	6	10	40	13	–	–	67	90	80	38	25			125	100			0.75	
LTB-A 6 – 120	561 561 20						80					130	120										1.12
LTB-A 7 – 80	561 570 80						40					90	80										0.96
LTB-A 7 – 100	561 571 00	80	38.5	16.5	8	12	65	13	–	–	77	110	100	45	35			145	115				1.20
LTB-A 7 – 150	561 571 50						2×60					160	150										1.75
LTB-A 8 – 120	561 581 20						60					130	120										2.24
LTB-A 8 – 160	561 581 60						2×60					170	160									2.96	
LTB-A 8 – 200	561 582 00	90	45	20.5	13	12.25	2×70	17	38	M12 × 30	90	210	200	50	40	25	170	130				3.75	
LTB-A 8 – 240	561 582 40						3×60					250	240									4.47	
LTB-A 8 – 320	561 583 20						4×60					330	320									6.06	

Material

Außenprofil: Aluminium
Innenprofil: Aluminium
Gummi: Basis auf SBR/Mischung Code C

Material

outer profile: Aluminium
core profile: Aluminium
rubber: SBR based/mixture code C

Leistungsparameter/performance parameters

Typ type	Art. Nr. art. no.	Drehmoment und max. Erregerfrequenz bei Winkel α Torque and max. excitation frequency at angle α																						
		Radial			Axial			α +/- 4°		α +/- 8°		α +/- 12°		α +/- 16°		α +/- 20°		α +/- 24°		α +/- 28°		α +/- 32°		
		Mc @ β +/- 1°	Federweg deflection	Belastung load	Federweg deflection	Belastung load	Nm	min ⁻¹	Nm	min ⁻¹	Nm	min ⁻¹	Nm	min ⁻¹	Nm	min ⁻¹	Nm	min ⁻¹	Nm	min ⁻¹	Nm	min ⁻¹	Nm	min ⁻¹
LTB-A 5 – 40	561 550 40	3.99		888		217	4.01		8.22		13.1		19.2		27		37		49.7		65.5			
LTB-A 5 – 60	561 550 60	12.01	0.5	1 333	0.5	325	6.02	990	12.4	300	19.8	170	29	110	40.9	68	56.2	43	75.6	30	100	10		
LTB-A 5 – 100	561 551 00	49.9		2 221		542	10		20.6		32.9		48.3		67.9		93.2		125		166			
LTB-A 6 – 60	561 560 60	11.74		1 564		372	11.3		23.7		38.5		56.7		79.6		108		144		188			
LTB-A 6 – 80	561 560 80	25.4	0.5	2 086	0.5	497	15.1	900	31.7	280	51.4	150	75.9	92	107	57	145	38	194	28	253	10		
LTB-A 6 – 120	561 561 20	78.3		3 130		745	22.6		47.5		77.1		114		160		218		291		380			
LTB-A 7 – 80	561 570 80	27		2 196		536	22.7		47.1		75.3		110		152		206		272		353			
LTB-A 7 – 100	561 571 00	52.2	0.5	2 745	0.5	669	28.4	850	58.9	250	94.1	150	137	86	190	57	256	36	338	26	439	10		
LTB-A 7 – 150	561 571 50	135		4 063		991	42.1		87.8		141		206		286		385		508		658			
LTB-A 8 – 120	561 581 20	89.5		3 442		840	72.9		139.5		209		289		390		519		685		898			
LTB-A 8 – 160	561 581 60	115.8		4 617		1 126	97.8		187.2		280		388		523		696		920		1 206			
LTB-A 8 – 200	561 582 00	288	0.5	5 772	0.5	1 408	122.2	840	234	250	350	150	485	85	654	53	870	36	1 150	24	1 506	10		
LTB-A 8 – 240	561 582 40	605		6 919		1 688	146.5		281		420		582		784		1 044		1 379		1 807			
LTB-A 8 – 320	561 583 20	1 677		9 231		2 252	195.4		374		560		776		1 046		1 393		1 840		2 411			

GUMMIFEDERELEMENT TYP LTB-A 9–12

RUBBER SUSPENSION UNIT TYPE LTB-A 9–12



RESATEC GUMMIFEDERELEMENT TYP LTB-A:

Ab Typ LTB-A 8 sind im Innenprofil Gewinde vorhanden. Die Befestigungsflansche sind nach genormten Massen geschweisst, können jedoch auch nach Kundenvorgabe geformt und positioniert werden. Das Element wird durch die vorhandenen Befestigungslöcher im Flansch direkt an gewünschter Position verschraubt. Für wechselseitige Auslenkung über die Element-Nulllage geeignet.

RESATEC RUBBER SUSPENSION UNIT TYPE LTB-A:

There are threads in the inner profile starting from type LTB-A 8. The mounting flanges are welded according to standardized dimensions, but can also be designed and positioned according to customer specifications. The element is bolted directly to the desired position through the existing mounting holes in the flange. Suitable for alternating deflection over the element zero position.

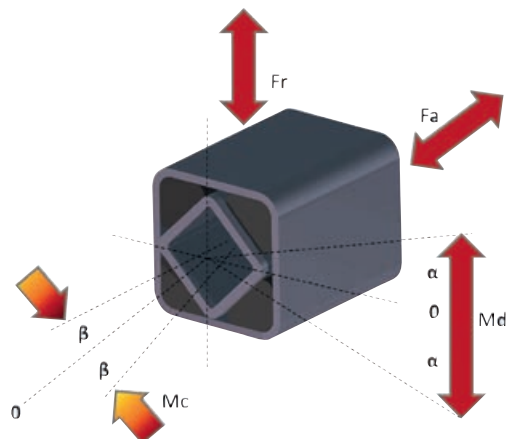
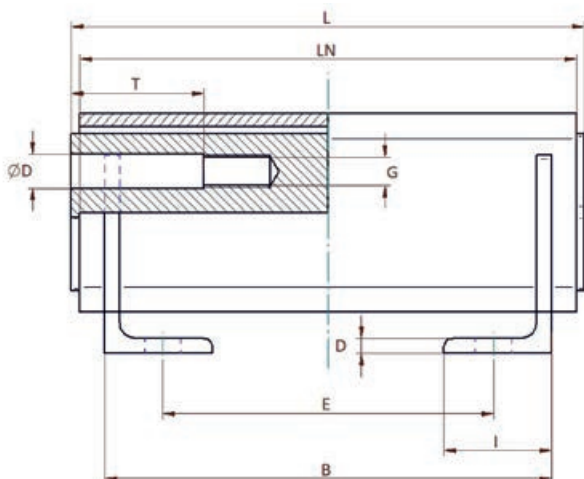
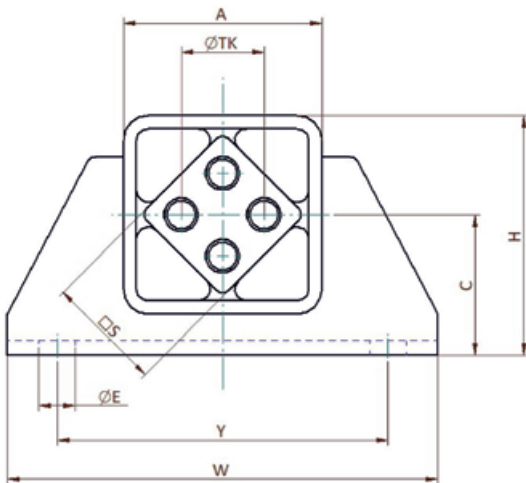

Typ type	Art. Nr. art. no.	A	B	C	D	øD	E	øE	G	H	I	L	LN	□S	T	øTk	W	Y	Gewicht weight	Verfügbarkeit availability
																			kg	am Lager on stock
LTB-A 9 – 150	561 591 50		130				60		M16 × 40			160	150						8.8	Lieferzeit auf Anfrage/delivery time on request Preis auf Anfrage/prices on request
LTB-A 9 – 200	561 592 00	100	170	65	8	16.5	100	18	M16 × 40	115	60	210	200	60	50	45	220	160	11.2	
LTB-A 9 – 300	561 593 00		270				200		M16 × 40			310	300						15.9	
LTB-A 10 – 200	561 510 20		170				100		M20 × 40			210	200						17.2	
LTB-A 10 – 300	561 510 30	120	270	80	9	20.5	200	22	M20 × 40	140	65	310	300	70	50	50	50	260	23.4	
LTB-A 10 – 400	561 510 40		370				300		M20 × 40			410	400						30.1	
LTB-A 11 – 200	561 511 20		170				80		M20 × 40			210	200						23.7	
LTB-A 11 – 300	561 511 30	140	270	85	10	20.5	180	22	M20 × 40	155	80	310	300	80	50	60	60	280	32.4	
LTB-A 11 – 400	561 511 40		370				280		M20 × 40			410	400						41.4	
LTB-A 12 – 250	561 512 25		220				110		M24 × 50			260	250						44	
LTB-A 12 – 400	561 512 40	170	370	110	12	25	260	26	M24 × 50	195	100	410	400	100	50	75	380	300	65.1	
LTB-A 12 – 500	561 512 50		470				360		M24 × 50			510	500						79.1	

Material

Aussenprofil: Stahl S235JR/pulverlackiert
 Innenprofil: Stahl S235JR/ohne Beschichtung
 Gummi: Basis auf SBR/Mischung Code C

Material

outer profile: Aluminium
 core profile: steel S235JR/without coating
 rubber: SBR based/mixture code C

Leistungsparameter/performance parameters

Typ type	Art. Nr. art. no.	MC @ β +/- 1°	Radial		Axial		Drehmoment und max. Erregerfrequenz bei Winkel α Torque and max. excitation frequency at angle α															
			Federweg deflection	Belastung load	Federweg deflection	Belastung load	α +/- 4°		α +/- 8°		α +/- 12°		α +/- 16°		α +/- 20°		α +/- 24°		α +/- 28°		α +/- 32°	
			Nm	Sr mm	Fr N	Sa mm	Fa N	Nm	min ⁻¹	Nm	min ⁻¹	Nm	min ⁻¹	Nm	min ⁻¹	Nm	min ⁻¹	Nm	min ⁻¹	Nm	min ⁻¹	Nm
LTB-A 9 – 150	561 591 50	107		5 160		1 613	61.6	800	130		214		325		472		666		916		1 233	
LTB-A 9 – 200	561 592 00	296	1	6 880	1	2 150	82.1		173	250	285	130	433	82	629	50	887	38	1 221	23	1 643	10
LTB-A 9 – 300	561 593 00	1 065		10 417		3 255	124		273		464		714		1 042		1 463		1 995		2 657	
LTB-A 10 – 200	561 510 20	315		8 334		2 315	125	740	284		487		742		1 058		1 445		1 912		2 467	
LTB-A 10 – 300	561 510 30	1 350	1	11 654	1	3 237	175		392	230	672	130	1 035	78	1 499	48	2 085	33	2 812	23	3 700	10
LTB-A 10 – 400	561 510 40	2 475		18 024		5 007	270		577		965		1 475		2 151		3 036		4 173		5 604	
LTB-A 11 – 200	561 511 20	904		10 281		2 570	187	685	401		659		978		1 373		1 863		2 463		3 190	
LTB-A 11 – 300	561 511 30	1 993	1	15 422	1	3 855	281		602	210	989	130	1 467	73	2 060	43	2 794	28	3 694	23	4 784	10
LTB-A 11 – 400	561 511 40	6 115		20 550		5 138	375		816		1 352		2 013		2 829		3 828		5 039		6 493	
LTB-A 12 – 250	561 512 25	1 350		20 458		4 092	405		829		1 337		1 993		2 863		4 012		5 503		7 402	
LTB-A 12 – 400	561 512 40	4 838	1	32 735	1	6 547	648	620	1 326	190	2 139	110	3 189	63	4 581	38	6 419	28	8 805	18	11 843	10
LTB-A 12 – 500	561 512 50	9 000		40 919		8 184	810		1 658		2 674		3 987		5 727		8 024		11 007		14 805	

GUMMIFEDERELEMENT TYP LTB-C

RUBBER SUSPENSION UNIT TYPE LTB-C

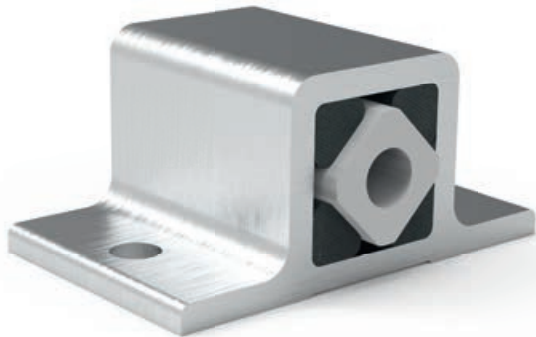

RESATEC GUMMIFEDERELEMENT TYP LTB-C:

Das Innenprofil Typ C ermöglicht die Befestigung mit zentraler Schraube. Es sind Schrauben der Qualität 8,8 zu verwenden. Das Aussengehäuse kann durch die Befestigungslöcher in der Flanschpartie direkt mit Schrauben der Qualität 8,8 befestigt werden. Für wechselseitige Auslenkung bis $\pm 10^\circ$ geeignet.

RESATEC RUBBER SUSPENSION UNIT TYPE LTB-C:

The inner profile type C enables fastening with central screw. Screws of quality 8.8 must be used. The outer housing can be fastened directly with quality 8.8 screws through the fastening holes in the flange section. Suitable for alternating deflection up to $\pm 10^\circ$.

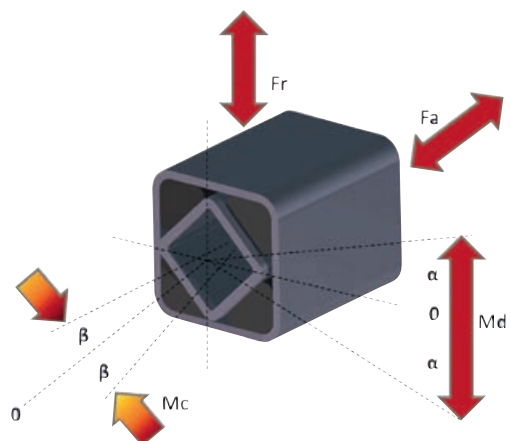
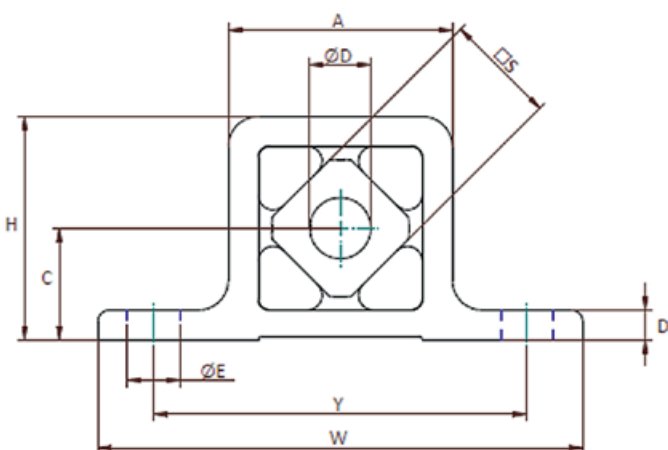

Abmasse/Material/dimensions/material

Typ type	Art. Nr. art. no.	A	W	H	C	D	□S	LN	L	øD	E	øE	Y	Gewicht weight	Material		
															Aussenprofil outer profile	Innenprofil core profile	Gummi rubber
LTB-C 5 – 40	561 650 40							40	45		–			0.21	Aluminium	Aluminium	Basis auf SBR/Mischung Code C SBR based/mixture code C
LTB-C 5 – 60	561 650 60	49	105	50	25.5	5	27	60	65	16	–	11	80	0.32			
LTB-C 5 – 100	561 651 00							100	105		60			0.51			
LTB-C 6 – 60	561 660 60							60	70		–			0.58			
LTB-C 6 – 80	561 660 80	66	125	67	34	6	38	80	90	20	40	13	100	0.74			
LTB-C 6 – 120	561 661 20							120	130		80			1.12			

Leistungsparameter/performance parameters

Typ type	Art. Nr. art. no.	MC @ β +/- 1°	Radial		Axial		Drehmoment und max. Erregerfrequenz bei Winkel α Torque and max. excitation frequency at angle α															
			Federweg deflection	Belastung load	Federweg deflection	Belastung load	α +/- 4°		α +/- 8°		α +/- 12°		α +/- 16°		α +/- 20°		α +/- 24°		α +/- 28°		α +/- 32°	
			Nm	Sr mm	Fr N	Sa mm	Fa N	Nm	min ⁻¹	Nm	min ⁻¹	Nm	min ⁻¹	Nm	min ⁻¹	Nm	min ⁻¹	Nm	min ⁻¹	Nm	min ⁻¹	Nm
LTB-C 5 – 40	561 650 40	3.99		888		217	4.01		8.22		13.1		19.2		27		37		49.7		65.5	
LTB-C 5 – 60	561 650 60	12.01	0.5	1 333	0.5	325	6.02	990	12.4	300	19.8	170	29	110	40.9	68	56.2	43	75.6	30	100	10
LTB-C 5 – 100	561 651 00	49.9		2 221		542	10		20.6		32.9		48.3		67.9		93.2		125		166	
LTB-C 6 – 60	561 660 60	11.74		1 564		372	11.3		23.7		38.5		56.7		79.6		108		144		188	
LTB-C 6 – 80	561 660 80	25.4	0.5	2 086	0.5	497	15.1	900	31.7	280	51.4	150	75.9	92	107	57	145	38	194	28	253	10
LTB-C 6 – 120	561 661 20	78.3		3 130		745	22.6		47.5		77.1		114		160		218		291		380	

GUMMIFEDERELEMENT TYP LTB-S

RUBBER SUSPENSION UNIT TYPE LTB-S



RESATEC GUMMIFEDERELEMENT TYP LTB-S:

Das Innenprofil Typ S ermöglicht eine Steckverbindung. Die Einstecktiefe des gesteckten Vierkantes soll mindestens dem 1,8-fachen des Materialquerschnittes (Mass S) entsprechen. Als Vierkant soll ein blanker Stahl mit der Toleranz h11 und facettierten Kanten verwendet werden. Das Aussengehäuse kann durch die Befestigungslöcher in der Flanschpartie direkt mit Schrauben der Qualität 8,8 befestigt werden. Eine wechselseitige Auslenkung über die Element-Nulllage ist nicht möglich.

RESATEC RUBBER SUSPENSION UNIT TYPE LTB-S:

The inner profile type S enables a plug-in connection. The insertion depth of the inserted square should be at least 1.8 times the material cross-section (dimension S). The square should be made of bright steel with tolerance h11 and faceted edges. The outer housing can be fastened directly with quality 8.8 screws through the fastening holes in the flange section. An alternating deflection over the element zero position is not possible.

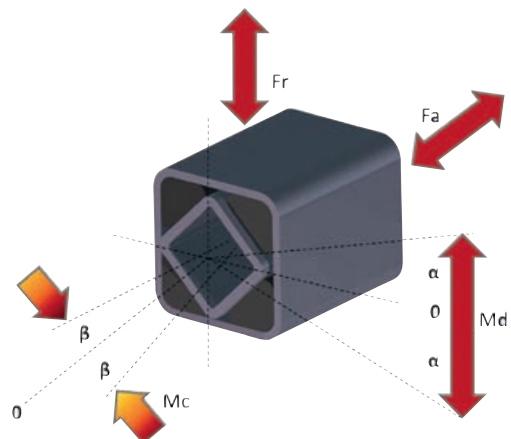
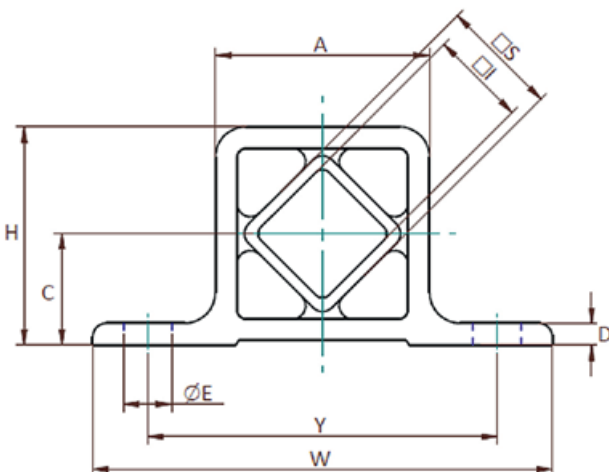

Typ type	Art. Nr. art. no.	A	C	D	E	øE	øF	H	□I	L	LN	□S	W	Y	Gewicht weight kg	Material																											
		mm	mm	mm	mm	mm	mm	mm	mm	mm	mm	mm	mm	mm		mm	Aussenprofil outer profile	Innenrohr/core square tube	Gummi rubber																								
LTB-S 3 – 40	561 430 40	27	15	4	–	7	–	30	11	45	40	15	65	50	2.18	SINT-C 40	Stahl S235JR/galvanisch verzinkt steel S235JR/galvanized	Basis auf SBR/Mischung Code C SBR based/mixture code C																									
LTB-S 5 – 40	561 450 40				–					45	40				0.24	Aluminium																											
LTB-S 5 – 60	561 450 60	49	25.5	5	–	11	–	50	22	65	60	27	105	80	0.35																												
LTB-S 5 – 100	561 451 00				60					105	100				0.57																												
LTB-S 6 – 60	561 460 60				–		–			70	60				0.65																												
LTB-S 6 – 80	561 460 80	66	34	6	40	13		67	30	90	80	38	125	100	0.83																												
LTB-S 6 – 120	561 461 20				80					130	120				1.24																												
LTB-S 7 – 80	561 470 80				40		–			90	80				1.2																												
LTB-S 7 – 100	561 471 00	80	38.4	8	65	13		77	35	110	100	45	145	115	1.49																												
LTB-S 7 – 150	561 471 50				2×60					160	150				2.18																												
LTB-S 8 – 120	561 481 20				60					130	120				2.55																												
LTB-S 8 – 160	561 481 60				2×60					170	160				3.35																												
LTB-S 8 – 200	561 482 00	80	45	13	2×70	17	38	90	40	210	200	50	170	130	4.23																												
LTB-S 8 – 240	561 482 40				3×60					250	240				5.03																												
LTB-S 8 – 320	561 483 20				4×60					330	320				6.78																												

Leistungsparameter/performance parameters

Typ type	Art. Nr. art. no.	MC@β +/-1°	Drehmoment und max. Erregerfrequenz bei Winkel α Torque and max. excitation frequency at angle α																			
			Radial		Axial		α +/- 4°		α +/- 8°		α +/- 12°		α +/- 16°		α +/- 20°		α +/- 24°		α +/- 28°		α +/- 32°	
			Federweg deflection	Belastung load	Federweg deflection	Belastung load	Nm	min ⁻¹	Nm	min ⁻¹	Nm	min ⁻¹	Nm	min ⁻¹	Nm	min ⁻¹	Nm	min ⁻¹	Nm	min ⁻¹	Nm	min ⁻¹
LTB-S 3 – 40	561 430 40	2	Sr mm	Fr N	Sa mm	Fa N	1	1 100	2.2	330	3.5	190	5.1	120	7	72	9.2	46	11.7	33	14.7	10
LTB-S 5 – 40	561 450 40	3.99		888		217	4.01		8.22		13.1		19.2		27		37		49.7		65.5	
LTB-S 5 – 60	561 450 60	12.01	0.5	1 333	0.5	325	6.02	900	12.4	300	19.8	170	29	110	40.9	68	56.2	43	75.6	30	100	10
LTB-S 5 – 100	561 451 00	49.9		2 221		542	10		20.6		32.9		48.3		67.9		93.2		125		166	
LTB-S 6 – 60	561 460 60	11.74		1 564		372	11.3		23.7		38.5		56.7		79.6		108		144		188	
LTB-S 6 – 80	561 460 80	25.4	0.5	2 086	0.5	497	15.1	900	31.7	280	51.4	150	75.9	92	107	57	145	38	194	28	253	10
LTB-S 6 – 120	561 461 20	78.3		3 130		745	22.6		47.5		77.1		114		160		218		291		380	
LTB-S 7 – 80	561 470 80	27		2 196		536	22.7		47.1		75.3		110		152		206		272		353	
LTB-S 7 – 100	561 471 00	52.2	0.5	2 745	0.5	669	28.4	850	58.9	250	94.1	150	137	86	190	57	256	36	338	26	439	10
LTB-S 7 – 150	561 471 50	135		4 063		991	42.1		87.8		141		206		286		385		508		658	
LTB-S 8 – 120	561 481 20	89.5		3 442		840	72.9		139.5		209		289		390		519		685		898	
LTB-S 8 – 160	561 481 60	115.8		4 617		1 126	97.8		187.2		280		388		523		696		920		1 206	
LTB-S 8 – 200	561 482 00	288	0.5	5 772	0.5	1 408	122.2	840	234	250	350	150	485	85	654	53	870	36	1 150	24	1 506	10
LTB-S 8 – 240	561 482 40	605		6 919		1 688	146.5		281		420		582		784		1 044		1 379		1 807	
LTB-S 8 – 320	561 483 20	1 677		9 231		2 252	195.4		374		560		776		1 046		1 393		1 840		2 411	

GUMMIFEDERELEMENT TYP LTK-A

RUBBER SUSPENSION UNIT TYPE LTK-A



RESATEC GUMMIFEDERELEMENT TYP LTK-A:

Das Innenprofil Typ A ermöglicht die Befestigung mit Schrauben. Bis zum Typ LTK 7 sind durchgehende Schrauben der Qualität 8,8 zu verwenden. Ab dem Typ LTK 8 sind im Innenprofil Gewinde vorhanden. Eine weitere einfache Einbaumöglichkeit bietet der RESATEC *Montagewinkel Typ MA*. Aussen wird das Gummifederelement in eine Klemmfaust gesteckt oder mit der RESATEC *Montagebride CK* befestigt.

RUBBER SUSPENSION UNIT TYPE LTK-A:

The inner profile type A allows fastening with screws. Up to type LTK 7, screws of quality 8.8 must be used. From type LTK 8, there are threads in the inner profile. Another simple installation option is the RESATEC *mounting bracket type MA*. On the outside, the rubber spring element is inserted into a clamp or fastened with the RESATEC *mounting bracket type CK*.



PASSENDEN MONTAGEHALTERUNG TYP CK/MA
SEITE 38

MATCHING MOUNTING BRACKET TYPE CK/MA
PAGE 38

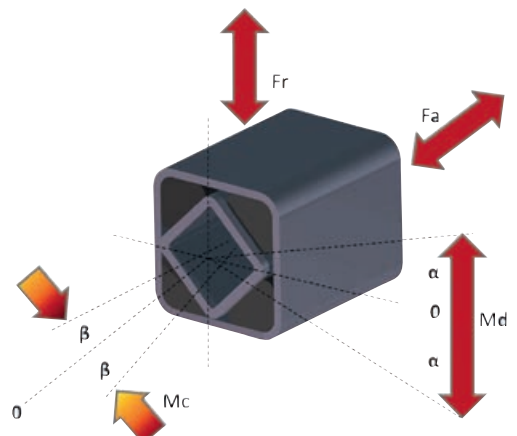
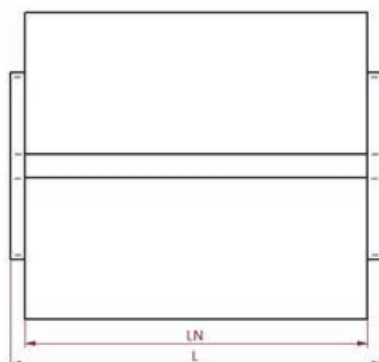
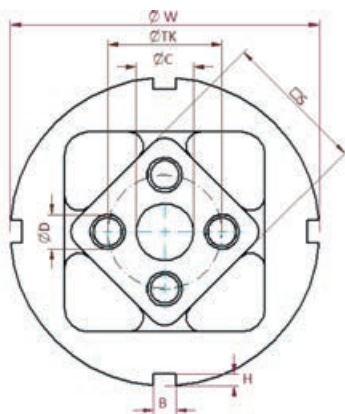

Typ type	Art. Nr. art. no.	øW	B	H	□S	LN	L	øTK	øD	øC	Anzahl Briden no. of mounting brackets	Gewicht weight	Material															
													Aussenrohr outer square tube	Innenrohr/core square tube	Gummi rubber													
													mm	mm	mm	mm	mm	mm	mm	mm	mm	mm	mm	Typ/type MS	kg			
LTK-A 4 – 30	560 240 30					30	35				1	0.1	Stahl S235JR/galvanisch verzinkt steel S235JR/galvanized	Aluminium	Basis auf SBR/Mischung Code C SBR based/mixture code C													
LTK-A 4 – 50	560 240 50	45	5	2.5	18	50	55	12	6	–	1	0.16																
LTK-A 4 – 80	560 240 80					80	85				2	0.25																
LTK-A 5 – 40	560 250 40					40	45				1	0.25																
LTK-A 5 – 60	560 250 60	62	6	3	27	60	65	20	8	–	1	0.37																
LTK-A 5 – 100	560 251 00					100	105				2	0.61																
LTK-A 6 – 60	560 260 60					60	70				1	0.61																
LTK-A 6 – 80	560 260 80	80	3×7 + 1×8.5	3×4 + 1×7.5	38	80	90	25	10	–	2	0.8																
LTK-A 6 – 120	560 261 20					120	130			2	1.19																	
LTK-A 7 – 80	560 270 80					80	90				1	1.08																
LTK-A 7 – 100	560 271 00	95	8	4	45	100	110	35	12	16.8	2	1.35																
LTK-A 7 – 150	560 271 50					150	160				2	2																
LTK-A 8 – 120	560 281 20					120	130				2	2.28																
LTK-A 8 – 200	560 282 00	108	8	4	50	200	210	40	ø10 + M12×40		4	3.77																
LTK-A 8 – 300	560 283 00					300	310					5				5.63												

Leistungsparameter/performance parameters

Typ type	Art. Nr. art. no.	MC @ β ±1°	Radial		Axial		Drehmoment und max. Erregerfrequenz bei Winkel α Torque and max. excitation frequency at angle α																
			Federweg deflection	Belastung load	Federweg deflection	Belastung load	α +/- 4°		α +/- 8°		α +/- 12°		α +/- 16°		α +/- 20°		α +/- 24°		α +/- 28°		α +/- 32°		
			Nm	Sr mm	Fr N	Sa mm	Fa N	Nm	min ⁻¹	Nm	min ⁻¹	Nm	min ⁻¹	Nm	min ⁻¹	Nm	min ⁻¹	Nm	min ⁻¹	Nm	min ⁻¹	Nm	min ⁻¹
			LTK-A 4 – 30	560 240 30	1.51		386		92	1.6	3.37		5.38		7.71		10.4		13.6		17.4		21.8
LTK-A 4 – 50	560 240 50	6.68	0.5	644	0.5	153	2.67	1050	5.64	330	9.07	190	13.1	110	17.9	72	23.6	46	30.4	33	38.4	10	
LTK-A 4 – 80	560 240 80	26.9		1030		245	4.27		9.01		14.5		20.8		28.3		37.3		47.8		60.2		
LTK-A 5 – 40	560 250 40	3.99		888		217	4.01		8.22		13.1		19.2		27		37		49.7		65.5		
LTK-A 5 – 60	560 250 60	12.01	0.5	1333	0.5	325	6.02	990	12.4	300	19.8	170	29	110	40.9	68	56.2	43	75.4	30	100	10	
LTK-A 5 – 100	560 251 00	49.9		2221		542	10		20.6		32.9		48.3		67.9		93.2		125		166		
LTK-A 6 – 60	560 260 60	11.74		1564		372	11.3		23.7		38.5		56.7		79.6		108		144		188		
LTK-A 6 – 80	560 260 80	25.4	0.5	2086	0.5	497	15.1	900	31.7	280	51.4	150	75.9	92	107	57	145	38	194	28	253	10	
LTK-A 6 – 120	560 261 20	78.4		3130		745	22.6		47.5		77.1		114		160		218		291		380		
LTK-A 7 – 80	560 270 80	27		2196		536	22.7		47.1		75.3		110		152		206		272		353		
LTK-A 7 – 100	560 271 00	52.2	0.5	2745	0.5	669	28.4	850	58.9	250	94.1	150	137	86	190	57	256	36	338	26	439	10	
LTK-A 7 – 150	560 271 50	135		4063		991	42.1		87.8		141		206		286		385		508		658		
LTK-A 8 – 120	560 281 20	81.8		2828		690	37.2		94.2		171		267		382		517		671		844		
LTK-A 8 – 200	560 282 00	263	0.5	5712	0.5	1393	74.6	840	184	250	329	150	509	85	723	53	971	36	1254	24	1570	10	
LTK-A 8 – 300	560 283 00	1355		8654		2110	183		350		525		776		980		1305		1725		2260		

GUMMIFEDERELEMENT TYP LTK-C

RUBBER SUSPENSION UNIT TYPE LTK-C



RESATEC GUMMIFEDERELEMENT TYP LTK-C:

Das Innenprofil Typ C ermöglicht die Befestigung mit zentraler Schraube. Es sind Schrauben der Qualität 8,8 zu verwenden. Ausen wird das Gummifederelement in eine Klemmfaust gesteckt oder mit der RESATEC *Montagebride CK* befestigt.

RUBBER SUSPENSION UNIT TYPE TYPE LTK-C:

The inner profile type C enables fastening with central screw. Screws of quality 8.8 must be used. On the outside, the rubber spring element is inserted into a clamp or fastened with the *RESATEC mounting bracket type CK*.

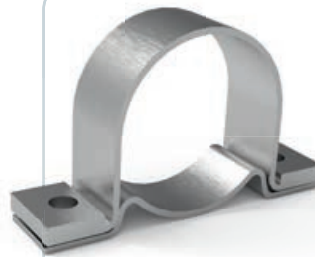

PASSENDEN MONTAGEHALTERUNG TYP CK
SEITE 38

MATCHING MOUNTING BRACKET TYPE MS
PAGE 38

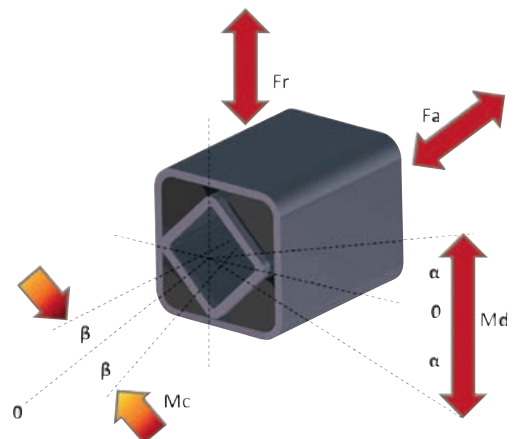
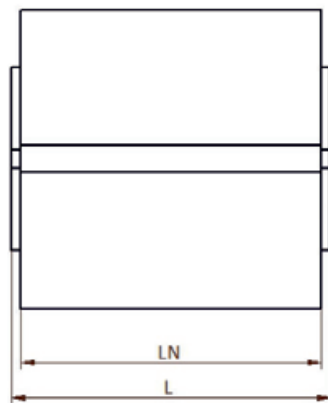
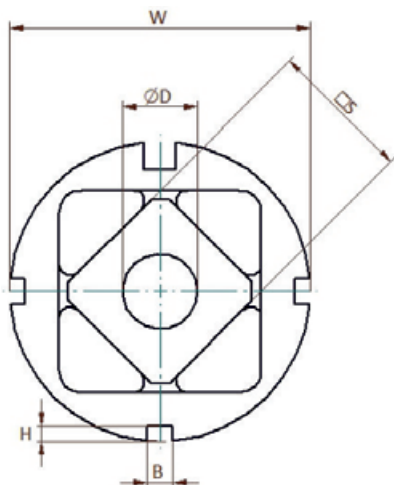

Typ type	Art. Nr. art. no.	øW	B	H	□S	LN	L	øD	Anzahl Briden no. of mounting brackets	Gewicht weight	Material		
											Aussenprofil outer profile	Innenprofil core profile	Gummi rubber
		mm	mm	mm	mm	mm	mm	^{+0,5} ₀ mm	Typ/type MS	kg			
LTK-C 5 – 40	560 650 40					40	45		1	0.25	Aluminium	Aluminium	Basis auf SBR/Mischung Code C SBR based/mixture code C
LTK-C 5 – 60	560 650 60	62	6	3	27	60	65	16	1	0.37			
LTK-C 5 – 100	560 651 00					100	105		2	0.61			
LTK-C 6 – 60	560 660 60	80	3×7 + 1×8.5	3×4 + 1×7.5	38	60	70		1	0.61	Aluminium	Aluminium	Basis auf SBR/Mischung Code C SBR based/mixture code C
LTK-C 6 – 80	560 660 80					80	90	20	2	0.8			
LTK-C 6 – 120	560 661 20					120	130	2	1.19				

Leistungsparameter/performance parameters

Typ type	Art. Nr. art. no.	MC @ β +/- 1°	Radial		Axial		Drehmoment und max. Erregerfrequenz bei Winkel α Torque and max. excitation frequency at angle α															
			Federweg deflection	Belastung load	Federweg deflection	Belastung load	α +/- 4°		α +/- 8°		α +/- 12°		α +/- 16°		α +/- 20°		α +/- 24°		α +/- 28°		α +/- 32°	
			Nm	Sr mm	Fr N	Sa mm	Fa N	Nm	min ⁻¹	Nm	min ⁻¹	Nm	min ⁻¹	Nm	min ⁻¹	Nm	min ⁻¹	Nm	min ⁻¹	Nm	min ⁻¹	Nm
LTK-C 5 – 40	560 650 40	3.99		888		217	4.01		8.22		13.1		19.2		27		37		49.7		65.5	
LTK-C 5 – 60	560 650 60	12.01	0.5	1 333	0.5	325	6.02	990	12.4	300	19.8	170	29	110	40.9	68	56.2	43	75.6	30	100	10
LTK-C 5 – 100	560 651 00	49.9		2 221		542	10		20.6		32.9		48.3		67.9		93.2		125		166	
LTK-C 6 – 60	560 660 60	11.74		1 564		372	11.3		23.7		38.5		56.7		79.6		108		144		188	
LTK-C 6 – 80	560 660 80	25.4	0.5	2 086	0.5	497	15.1	900	31.7	280	51.4	150	75.9	92	107	57	145	38	194	28	253	10
LTK-C 6 – 120	560 661 20	78.3		3 130		745	22.6		47.5		77.1		114		160		218		291		380	

GUMMIFEDERELEMENT TYP LTK-S

RUBBER SUSPENSION UNIT TYPE LTK-S



RESATEC GUMMIFEDERELEMENT TYP LTK-S:

Das Innenprofil Typ S ermöglicht eine Steckverbindung. Die Einstecktiefe des gesteckten Vierkantes soll mindestens dem 1,8-fachen des Materialquerschnittes (Mass S) entsprechen. Als Vierkant soll ein blanker Stahl mit der Toleranz h11 und facettierten Kanten verwendet werden. Aussen wird das Gummifederelement in eine Klemmfaust gesteckt oder mit der RESATEC *Montagebride CK* befestigt.

RESATEC RUBBER SUSPENSION UNIT TYPE LTK-S:

The inner profile TYPE S enables a plug-in connection. The insertion depth of the inserted square should be at least 1.8 times the material cross-section (dimension S). The square should be made of bright steel with tolerance h11 and faceted edges. On the outside, the rubber spring element is inserted into a clamping fist or fastened with the RESATEC *clamp mounting Type CK*.



PASSENDE MONTAGEHALTERUNG TYP CK
SEITE 38

MATCHING MOUNTING BRACKET TYPE MS
PAGE 38

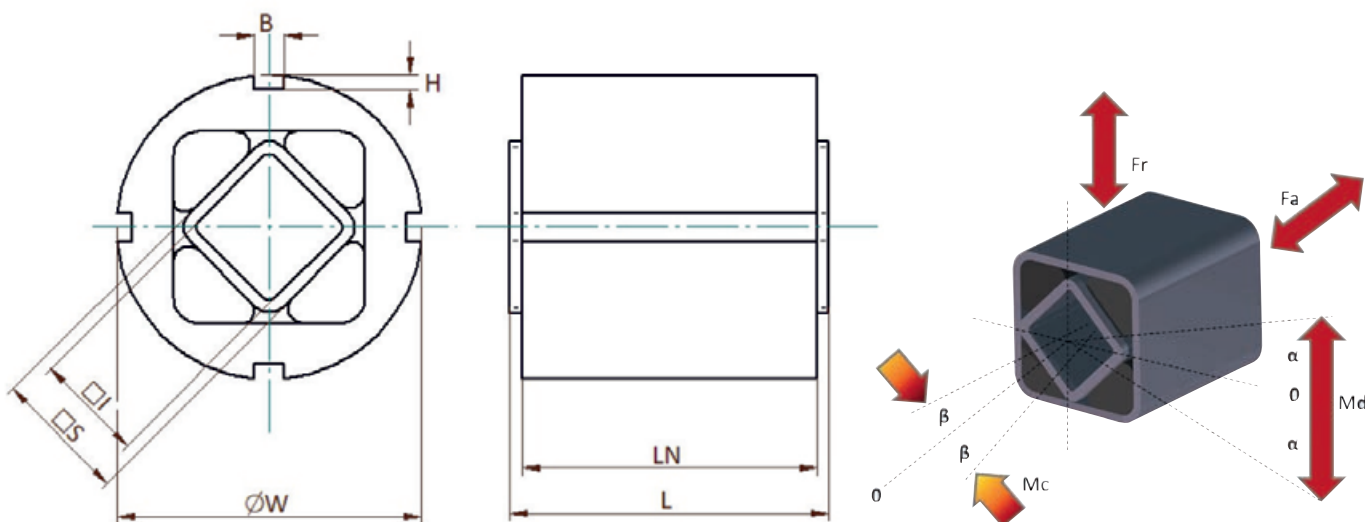

Typ type	Art. Nr. art. no.	øW	B	H	□S	LN	L	□I	Anzahl Briden no. of mounting brackets	Gewicht weight	Material			
											Aussenprofil outer profile	Innenrohr core square tube	Gummi rubber	
		mm	mm	mm	mm	mm	mm	mm	Typ/type MS	kg				
LTK-S 4 – 30	560 340 30					30	35		1	0.11	Aluminium	Stahl S235JR/galvanisch verzinkt steel S235JR/galvanized	Gummi Basis auf SBR/Mischung Code C SBR based/mixture code C	
LTK-S 4 – 50	560 340 50	45	5	2.5	18	50	55	12	1	0.18				
LTK-S 4 – 80	560 340 80					80	85		2	0.28				
LTK-S 5 – 40	560 350 40					40	45		1	0.27				
LTK-S 5 – 60	560 350 60	62	6	3	27	60	65	22	1	0.4				
LTK-S 5 – 100	560 351 00					100	105		2	0.66				
LTK-S 6 – 60	560 360 60		3 × 7 + 1 × 8.5	3 × 4 + 1 × 7.5		60	70		1	0.68				
LTK-S 6 – 80	560 360 80	80				38	80	90	30	2				0.89
LTK-S 6 – 120	560 361 20					120	130		2	1.31				
LTK-S 7 – 80	560 370 80					80	90		1	1.33				
LTK-S 7 – 100	560 371 00	95	8	4	45	100	110	35	2	1.64				
LTK-S 7 – 150	560 371 50					150	160		2	2.43				
LTK-S 8 – 120	560 381 20					120	130		2	2.55				
LTK-S 8 – 200	560 382 00	108	8	4	50	200	210	40	4	4.21				
LTK-S 8 – 300	560 383 00					300	310		5	6.28				

Leistungsparameter/performance parameters

Typ type	Art. Nr. art. no.	MC @ β +/-1°	Radial		Axial		Drehmoment und max. Erregerfrequenz bei Winkel α Torque and max. excitation frequency at angle α															
			Federweg deflection	Belastung load	Federweg deflection	Belastung load	α +/- 4°	α +/- 8°	α +/- 12°	α +/- 16°	α +/- 20°	α +/- 24°	α +/- 28°	α +/- 32°								
			Nm	Sr mm	Fr N	Sa mm	Fa N	Nm	min ⁻¹	Nm	min ⁻¹	Nm	min ⁻¹	Nm	min ⁻¹	Nm	min ⁻¹	Nm	min ⁻¹	Nm	min ⁻¹	
LTK-S 4 – 30	560 340 30	1.51		386		92	1.6	3.37		5.38		7.71		10.4		13.6		17.4		21.8		
LTK-S 4 – 50	560 340 50	6.68	0.5	644	0.5	153	2.67	1050	5.64	330	9.07	190	13.1	110	17.9	72	23.6	46	30.4	33	38.4	10
LTK-S 4 – 80	560 340 80	26.90		1030		245	4.27		9.01		14.5		20.8		28.3		37.3		47.8		60.2	
LTK-S 5 – 40	560 350 40	3.99		888		217	4.01		8.22		13.1		19.2		27		37		49.7		65.5	
LTK-S 5 – 60	560 350 60	12.01	0.5	1333	0.5	325	6.02	990	12.4	300	19.8	170	29.0	110	40.9	68	56.2	43	75.4	30	100	10
LTK-S 5 – 100	560 351 00	49.9		2221		542	10		20.6		32.9		48.3		67.9		93.2		125		166	
LTK-S 6 – 60	560 360 60	11.74		1564		372	11.3		23.7		38.5		56.7		79.6		108		144		188	
LTK-S 6 – 80	560 360 80	25.4	0.5	2086	0.5	497	15.1	900	31.7	280	51.4	150	75.9	92	107	57	145	38	194	28	253	10
LTK-S 6 – 120	560 361 20	78.4		3130		745	22.6		47.5		77.1		114		160		218		291		380	
LTK-S 7 – 80	560 370 80	27.0		2196		536	22.7		47.1		75.3		110		152		206		272		353	
LTK-S 7 – 100	560 371 00	52.2	0.5	2745	0.5	669	28.4	850	58.9	250	94.1	150	137	86	190	57	256	36	338	26	439	10
LTK-S 7 – 150	560 371 50	135		4063		991	42.1		87.8		141		206		286		385		508		658	
LTK-S 8 – 120	560 381 20	81.8		2828		690	37.2		94.2		171		267		382		517		671		844	
LTK-S 8 – 200	560 382 00	263	0.5	5712	0.5	1393	74.6	840	184	250	329	150	509	85	723	53	971	36	1254	24	1570	10
LTK-S 8 – 300	560 383 00	1355		8654		2110	183		350		525		776		980		1305		1725		2260	

GUMMIFEDERELEMENT TYP LTD-A

RUBBER SUSPENSION UNIT TYPE LTD-A



RESATEC GUMMIFEDERELEMENT TYP LTD-A:

Das Innenprofil Typ A ermöglicht die Befestigung mit Schrauben. Bis zum Typ LTD-A 7 sind durchgehende Schrauben der Qualität 8,8 zu verwenden. Ab dem Typ LTD-A 8 sind im Innenprofil Gewinde vorhanden. Eine weitere einfache Adaption-Möglichkeit bietet der RESATEC-*Montagewinkel Typ MA*. Das Doppелеlement wird zur Realisierung von Serie- oder Parallelschaltungen verwendet.

RESATEC RUBBER SUSPENSION UNIT TYPE LTD-A:

The inner profile type A allows fastening with screws. Up to type LTD-A 7, screws of quality 8.8 must be used. From type LTD-A 8 there are threads in the inner profile. Another simple installation option is the RESATEC *mounting bracket type MA*. The double element is used for the realization of series or parallel connection.



PASSENDE MONTAGE- HALTERUNG TYP MA SEITE 38

MATCHING MOUNTING
BRACKET TYPE MA
PAGE 38

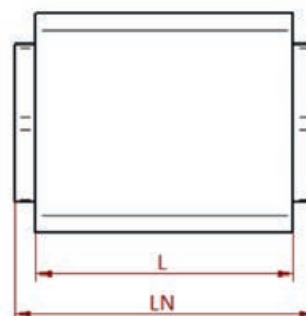
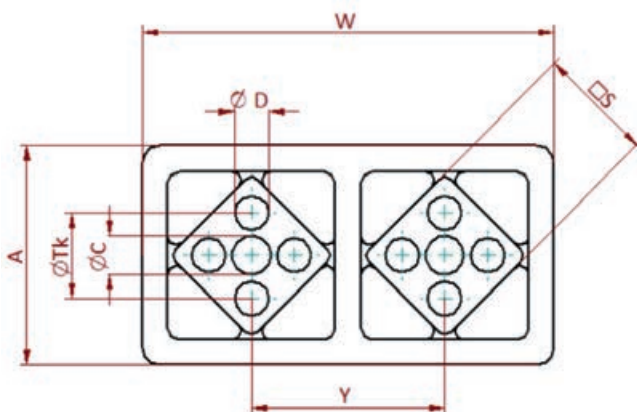

Typ type	Art. Nr. art. no.	A	øC	øD	G	L	LN	□S	T	øTk	W	Y	Gewicht weight kg	Material			
		mm	mm	mm	mm	mm	mm	mm	mm	mm	mm	mm		mm	Aussenprofil outer profile	Innenprofil core profile	Gummi rubber
LTD-A 5 – 40	562 550 40					45	40						0.34	Aluminium	Aluminium	Basis auf SBR/Mischung Code C SBR based/mixture code C	
LTD-A 5 – 60	562 550 60	49	–	8	–	65	60	27	Durchgangsbohrung/ through hole	20	93	45	0.51				
LTD-A 5 – 100	562 551 00					105	100						0.83				
LTD-A 6 – 60	562 560 60	66	–	10	–	70	60	38			25	126	60				0.96
LTD-A 6 – 80	562 560 80					90	80										1.25
LTD-A 6 – 120	562 561 20					130	120										1.85
LTD-A 7 – 80	562 570 80	84	16.5	12	–	90	80	45			35	149	72				1.77
LTD-A 7 – 100	562 571 00					110	100										2.19
LTD-A 7 – 150	562 571 50					160	150										3.25
LTD-A 8 – 120	562 581 20	92.5	20.5	12.25	ø10 + M12 x 30	130	120	50		25	40	168	78				3.47
LTD-A 8 – 160	562 581 60					170	160										4.61
LTD-A 8 – 200	562 582 00					210	200										5.74
LTD-A 8 – 240	562 582 40					250	240							6.88			
LTD-A 8 – 320	562 583 20					330	320		9.15								

Leistungsparameter/performance parameters

Typ type	Art. Nr. art. no.	MC @ β +/- 1°	Radial		Axial		Drehmoment und max. Erregerfrequenz bei Winkel α Torque and max. excitation frequency at angle α															
			Federweg deflection	Belastung load	Federweg deflection	Belastung load	α +/- 4°		α +/- 8°		α +/- 12°		α +/- 16°		α +/- 20°		α +/- 24°		α +/- 28°		α +/- 32°	
			Nm	Sr mm	Fr N	Sa mm	Fa N	Nm	min ⁻¹	Nm	min ⁻¹	Nm	min ⁻¹	Nm	min ⁻¹	Nm	min ⁻¹	Nm	min ⁻¹	Nm	min ⁻¹	Nm
LTD-A 5 – 40	562 550 40	3.99		888		217	4.01		8.22		13.1		19.2		27		37		49.7		65.5	
LTD-A 5 – 60	562 550 60	12.01	0.5	1 333	0.5	325	6.02	990	12.4	300	19.8	170	29	110	40.9	68	56.2	43	75.6	30	100	10
LTD-A 5 – 100	562 551 00	49.9		2 221		542	10		20.6		32.9		48.3		67.9		93.2		125		166	
LTD-A 6 – 60	562 560 60	11.74		1 564		372	11.3		23.7		38.5		56.7		79.6		108		144		188	
LTD-A 6 – 80	562 560 80	25.4	0.5	2 086	0.5	497	15.1	900	31.7	280	51.4	150	75.9	92	107	57	145	38	194	28	253	10
LTD-A 6 – 120	562 561 20	78.3		3 130		745	22.6		47.5		77.1		114		160		218		291		380	
LTD-A 7 – 80	562 570 80	27		2 196		536	22.7		47.1		75.3		110		152		206		272		353	
LTD-A 7 – 100	562 571 00	52.2	0.5	2 745	0.5	669	28.4	850	58.9	250	94.1	150	137	86	190	57	256	36	338	26	439	10
LTD-A 7 – 150	562 571 50	135		4 063		991	42.1		87.8		141		206		286		385		508		658	
LTD-A 8 – 120	562 581 20	89.5		3 442		840	72.9		139.5		209		289		390		519		685		898	
LTD-A 8 – 160	562 581 60	115.8		4 617		1 126	97.8		187.2		280		388		523		696		920		1 206	
LTD-A 8 – 200	562 582 00	288	0.5	5 772	0.5	1 408	122.2	840	234	250	350	150	485	85	654	53	870	36	1 150	24	1 506	10
LTD-A 8 – 240	562 582 40	605		6 919		1 688	146.5		281		420		582		784		1 044		1 379		1 807	
LTD-A 8 – 320	562 583 20	1 677		9 231		2 252	195.4		374		560		776		1 046		1 393		1 840		2 411	

GUMMIFEDERELEMENT TYP LTD-C

RUBBER SUSPENSION UNIT TYPE LTD-C

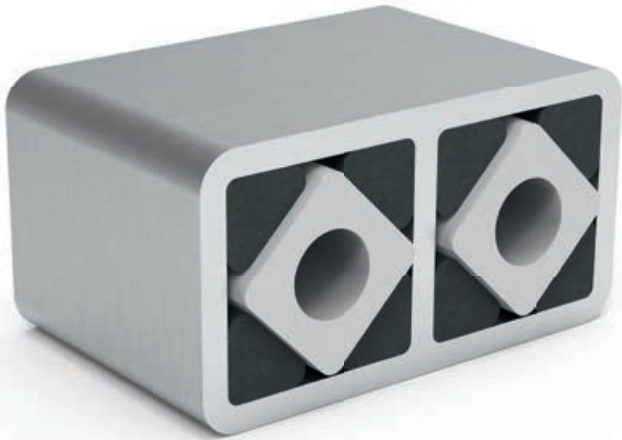

RESATEC GUMMIFEDERELEMENT TYP LTD-C:

Das Innenprofil Typ C ermöglicht die Befestigung mit zentraler Schraube. Es sind Schrauben der Qualität 8,8 zu verwenden. Das Doppelement wird zur Realisierung von Serie- oder Parallelschaltungen verwendet. Nur auf Anfrage verfügbar.

RESATEC RUBBER SUSPENSION UNIT TYPE LTD-C:

The inner profile type C enables fastening with central screw. Screws of quality 8.8 must be used. The double element is used for the realization of series or parallel circuits. Only available on request.

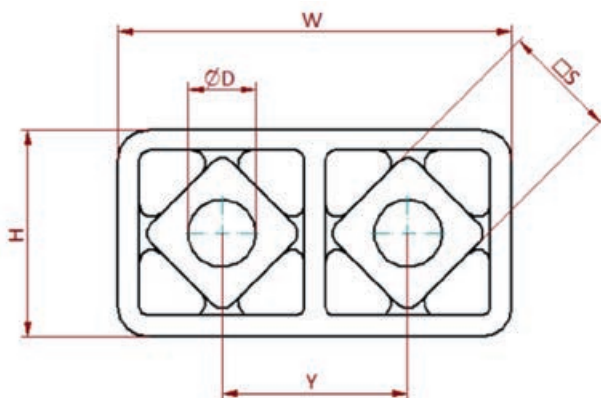

Abmasse/Material/dimensions/material

Typ type	Art. Nr. art. no.	øD +0,5 0 mm	H mm	L mm	LN mm	□S mm	W mm	Y mm	Gewicht weight kg	Material		
										Aussenprofil outer profile	Innenprofil core profile	Gummi rubber
LTD-C 5 – 40	562 650 40			45	40				0.34	Aluminium	Aluminium	Basis auf SBR /Mischung Code C SBR based /mixture code C
LTD-C 5 – 60	562 650 60	16	49	65	60	27	93	45	0.50			
LTD-C 5 – 100	562 651 00			105	100				0.83			
LTD-C 6 – 60	562 660 60			70	60				0.95			
LTD-C 6 – 80	562 660 80	20	66	90	80	38	126	60	1.25			
LTD-C 6 – 120	562 661 20			130	120				1.84			

Leistungsparameter/performance parameters

Typ type	Art. Nr. art. no.	MC @ β +/-1° Nm	Radial		Axial		Drehmoment und max. Erregerfrequenz bei Winkel α Torque and max. excitation frequency at angle α															
			Federweg deflection	Belastung load	Federweg deflection	Belastung load	α +/- 4°		α +/- 8°		α +/- 12°		α +/- 16°		α +/- 20°		α +/- 24°		α +/- 28°		α +/- 32°	
			Sr mm	Fr N	Sa mm	Fa N	Nm	min ⁻¹	Nm	min ⁻¹	Nm	min ⁻¹	Nm	min ⁻¹	Nm	min ⁻¹	Nm	min ⁻¹	Nm	min ⁻¹	Nm	min ⁻¹
LTD-C 5 – 40	562 650 40	3.99		888		217	4.01		8.22		13.1		19.2		27		37		49.7		65.5	
LTD-C 5 – 60	562 650 60	12.01	0.5	1'333	0.5	325	6.02	990	12.4	300	19.8	170	29	110	40.9	68	56.2	43	75.6	30	100	10
LTD-C 5 – 100	562 651 00	49.9		2'221		542	10		20.6		32.9		48.3		67.9		93.2		125		166	
LTD-C 6 – 60	562 660 60	11.74		1'564		372	11.3		23.7		38.5		56.7		79.6		108		144		188	
LTD-C 6 – 80	562 660 80	25.4	0.5	2'086	0.5	497	15.1	900	31.7	280	51.4	150	75.9	92	107	57	145	38	194	28	253	10
LTD-C 6 – 120	562 661 20	78.3		3'130		745	22.6		47.5		77.1		114		160		218		291		380	

GUMMIFEDERELEMENT TYP LTD-S

RUBBER SUSPENSION UNIT TYPE LTD-S

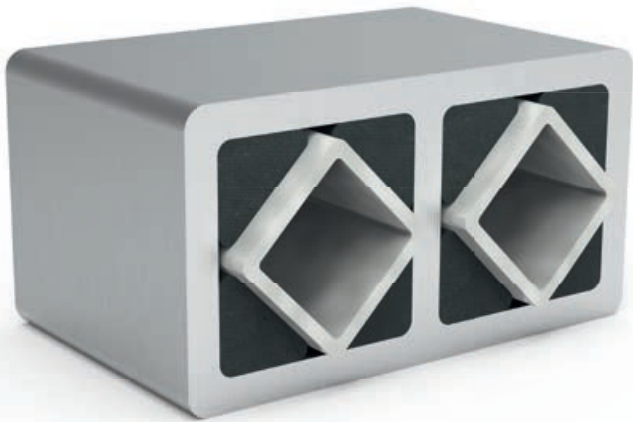

RESATEC GUMMIFEDERELEMENT TYP LTD-S:

Das Innenprofil Typ S ermöglicht eine Steckverbindung. Die Einstecktiefe des gesteckten Vierkantes soll mindestens dem 1,8-fachen des Materialquerschnittes (Mass S) entsprechen. Als Vierkant soll ein blanker Stahl mit der Toleranz h11 und facettierten Kanten verwendet werden. Das Doppelement wird zur Realisierung von Serie- oder Parallelschaltungen verwendet. Nur auf Anfrage verfügbar.

RESATEC RUBBER SUSPENSION UNIT TYPE LTD-S:

The inner profile type S enables a plug-in connection. The insertion depth of the inserted square should be at least 1.8 times the material cross-section (dimension S). The squares should be made of bright steel with tolerance h11 and faceted edges. The double element is used for the realization of series or parallel circuits. Only available on request.

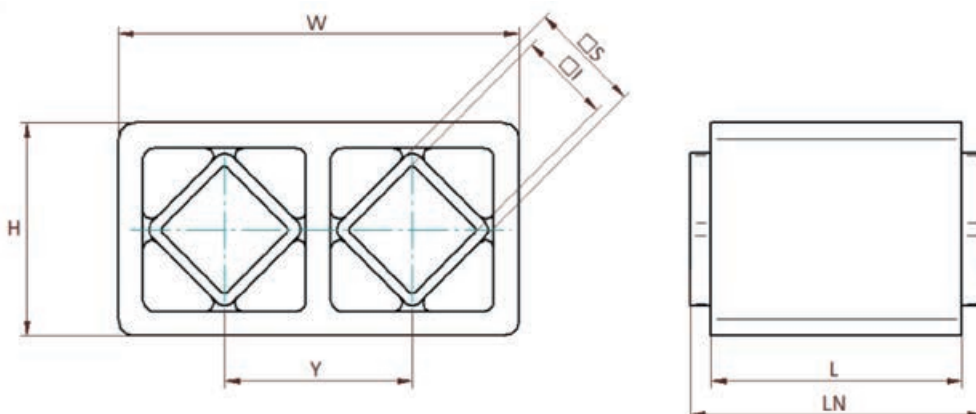

Typ type	Art. Nr. art. no.	W	H	□S	LN	L	□I	Y	Gewicht weight	Material		
										Außenprofil outer profile	Innenrohr core square tube	Gummi rubber
		mm	mm	mm	mm	mm	mm	mm	kg			
LTD-S 3 – 40	562 430 40	57	30	15	40	45	11	27	0.28	SINT-C 40	Stahl S235JR/galvanisch verzinkt steel S235JR/galvanized	Gummi rubber
LTD-S 5 – 40	562 450 40				40	45			0.39	Aluminium		
LTD-S 5 – 60	562 450 60	93	49	27	60	65	22	45	0.58			
LTD-S 5 – 100	562 451 00				100	105			0.95			
LTD-S 6 – 60	562 460 60				60	70			1.09			
LTD-S 6 – 80	562 460 80	126	66	38	80	90	30	60	1.42			
LTD-S 6 – 120	562 461 20				120	130			2.10			
LTD-S 7 – 80	562 470 80				80	90			2.25			
LTD-S 7 – 100	562 471 00	149	84	45	100	110	35	72	2.78			
LTD-S 7 – 150	562 471 50				150	160			4.11			
LTD-S 8 – 120	562 481 20				120	130			4.05			
LTD-S 8 – 160	562 481 60				160	170			5.36			
LTD-S 8 – 200	562 482 00	168	92.5	50	200	210	40	78	6.66			
LTD-S 8 – 240	562 482 40				240	250			7.97			
LTD-S 8 – 320	562 483 20				320	330			10.57			

Leistungsparameter/performance parameters

Typ type	Art. Nr. art. no.	MC@β +/-1°	Radial		Axial		Drehmoment und max. Erregerfrequenz bei Winkel α Torque and max. excitation frequency at angle α															
			Federweg deflection	Belastung load	Federweg deflection	Belastung load	α +/- 4°		α +/- 8°		α +/- 12°		α +/- 16°		α +/- 20°		α +/- 24°		α +/- 28°		α +/- 32°	
			Nm	Sr mm	Fr N	Sa mm	Fa N	Nm	min ⁻¹	Nm	min ⁻¹	Nm	min ⁻¹	Nm	min ⁻¹	Nm	min ⁻¹	Nm	min ⁻¹	Nm	min ⁻¹	Nm
LTD-S 3 – 40	562 430 40	2	0.25	343	0.25	111	1	1000	2.2	330	3.50	190	5.1	120	7.00	72	9.2	46	11.7	33	14.7	10
LTD-S 5 – 40	562 450 40	3.99		888		217	4.01		8.22		13.1		19.2		27		37		49.7		65.5	
LTD-S 5 – 60	562 450 60	12.01	0.5	1333	0.5	325	6.02	990	12.4	300	19.8	170	29	110	40.9	68	56.2	43	75.6	30	100	10
LTD-S 5 – 100	562 451 00	49.9		2221		542	10.0		20.6		32.9		48.3		76.9		93.1		125		166	
LTD-S 6 – 60	562 460 60	11.74		1564		372	11.3		23.7		38.5		56.7		79.6		108		144		188	
LTD-S 6 – 80	562 460 80	25.4	0.5	2086	0.5	497	15.1	900	31.7	280	51.4	150	75.9	92	107	57	145	38	194	28	253	10
LTD-S 6 – 120	562 461 20	78.3		3130		745	22.6		47.5		77.1		114		160		218		291		380	
LTD-S 7 – 80	562 470 80	27		2196		536	22.7		47.1		75.3		110		152		206		272		353	
LTD-S 7 – 100	562 471 00	52.2	0.5	2745	0.5	669	28.4	850	58.9	250	94.1	150	137	86	190	57	256	36	388	26	439	10
LTD-S 7 – 150	562 471 50	135		4063		991	42.1		87.8		141		206		286		385		508		658	
LTD-S 8 – 120	562 481 20	89.5		3443		840	72.9		139.5		209		289		390		519		685		898	
LTD-S 8 – 160	562 481 60	115.8		4617		1126	97.8		187.2		280		388		523		696		920		1206	
LTD-S 8 – 200	562 482 00	288	0.5	5772	0.5	1408	122.2	840	234	250	350	150	485	85	654	53	870	36	1150	24	1506	10
LTD-S 8 – 240	562 482 40	605		6919		1688	146.5		281		420		582		784		1044		1379		1807	
LTD-S 8 – 320	562 483 20	1677		9231		2252	195.4		374		560		776		1046		1393		1840		2411	

MONTAGEWINKEL TYP MA

MOUNTING BRACKET TYPE MA

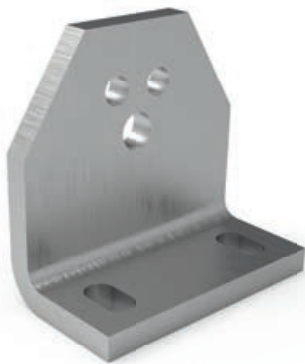

RESATEC MONTAGEBRIDE TYP MA:

Der Montagewinkel MA ermöglicht eine, einfache zur Grundfläche rechtwinklige Montage der RESATEC-Spannelemente LTA, LTK-A und LTD-A.

RESATEC MOUNTING BRACKET TYPE MA:

The MA mounting bracket enables easy mounting of the RESATEC LTA, LTK-A and LTD-A tensioners at right angles to the base surface.

MONTAGEBRIDE TYP CK/MS

MOUNTING BRACKET TYPE CK/MS



RESATEC MONTAGEBRIDE TYP CK:

Die RESATEC Montagebride Typ CK ermöglicht eine einfache Montage der REATEC-Gummifederelemente Typ LTK-S, LTK-A und LTK-C. Das Gummifederelement Typ LTK kann vor dem Festziehen der Schrauben in der Montagebride Typ CK frei gedreht werden. Dazu kann bis zu dem Typ CK 6 ein Hakenschlüssel nach DIN 1810 oder bei den grösseren Typen eine Gurtzange verwendet werden.

RESATEC MOUNTING BRACKET TYPE CK:

The RESATEC mounting bracket type CK allows easy mounting of the REATEC rubber spring elements type LTK-S, LTK-A and LTK-C. The rubber spring element type LTK can be rotated freely in the mounting bracket type CK before tightening the screws. For this purpose, a hook wrench according to DIN 1810 can be used up to type CK 6 or, in the case of the larger types, a strap wrench.

RESATEC MONTAGEBRIDE TYP MS:

Die RESATEC-Montagebride Typ MS ermöglicht eine einfache Montage der RESATEC-Gummifederelemente Typ LTS, LTA und LTC. Das Gummifederelement Typ LT kann vor dem Festziehen der Schrauben in der RESATEC-Montagebride Typ MS axial frei positioniert werden.

RESATEC CLAMP MOUNTING TYPE MS:

The RESATEC mounting bracket type MS allows easy mounting of the RESATEC rubber spring elements type LTS, LTA and LTC. The rubber spring element type LT can be freely positioned axially in the RESATEC mounting bracket type MS before tightening the screws.



Abmasse/Material/dimensions/material

Typ type	Art. Nr. art. no.	passend zu suitable for		øM	M	øA	A	øTK	T	U	V	X	Y	S	H	B	W	C	Gewicht weight	Material
		TE	LT-A																	
MA 2-3	580 002 03	2	3	6.5	27	5.5	35	10	10	12	7	13	30	4	46	30	50	25	0.1	Stahl galvanisch verzinkt/ steel galvanised
MA 3-4	580 003 04	3	4	8.5	34	6.5	44	123	10	14	7	13	40	6	58	32	60	30	0.2	
MA 4-5	580 004 05	4	5	10.5	45	8.5	55	20	10	16	9.5	16	50	6	75	38	70	40	0.3	
MA 5-6	580 005 06	5	6	12.5	75	10.5	75	25	12.5	21	11.5	22	65	8	98	52	90	58	0.7	
MA 6-7	580 006 07	6	7	16.5	66	12.5	85	35	15	21	14	24	80	8	116	55	110	56	0.9	Stahl mit Pulverlackierung/ steel with powder coating
MA 7-8	580 007 08	7	8	20.5	80	12.5	110	40	20	26	18	30	100	10	140	66	140	68	1.8	

Abmasse/Material/dimensions/material

Typ type	Art. Nr. art. no.	□A	Y	øC	W	L	H	S	Gewicht weight	Material
MS 3	580 000 30	27	50	6.5	65	25	29	2	0.04	Stahl galvanisch verzinkt/ steel galvanised
MS 4	580 000 40	32	60	8.5	80	30	34	3	0.09	
MS 5	580 000 50	45	80	10.5	105	35	48	3	0.16	
MS 6	580 000 60	60	100	12.5	125	40	65	5	0.29	Stahl mit Pulverlackierung/ steel with powder coating
MS 7	580 000 70	75	115	12.5	145	45	80	5	0.45	

Abmasse/Material/dimensions/material

Typ type	Art. Nr. art. no.	øD	Y	øC	Z	W	L	H	S	B	Gewicht weight	Material
CK 4	580 000 44	45	68	8.5	25	90	30	49.5	2	9	0.15	Stahl galvanisch verzinkt/ steel galvanised
CK 5	580 000 55	62	92	10.5	35	125	40	69	3	11.5	0.30	
CK 6	580 000 66	80	115	12.5	44	150	40	87	3	12.5	0.45	
CK 7	580 000 77	95	130	12.5	52.5	165	45	104	4	16	0.75	Stahl mit Pulverlackierung/ steel with powder coating
CK 8	580 000 88	108	152	16.5	59	195	50	117	4	18	0.95	

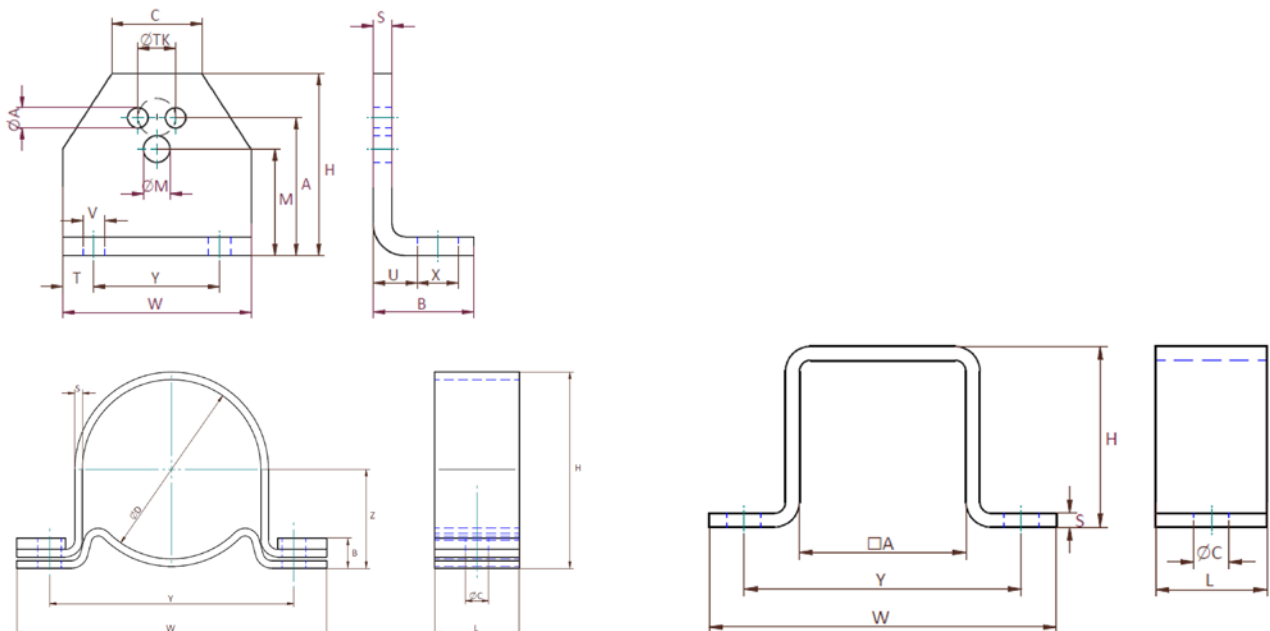

SPANNELEMENTE

TENSIONER DEVICES

TE/TE-I/TE-G/TE-FB/BOOMERANG

RE

CR/CRS/CRD

K/KS-SIMPLEX/KS-DUPLEX/KS-TRIPLEX

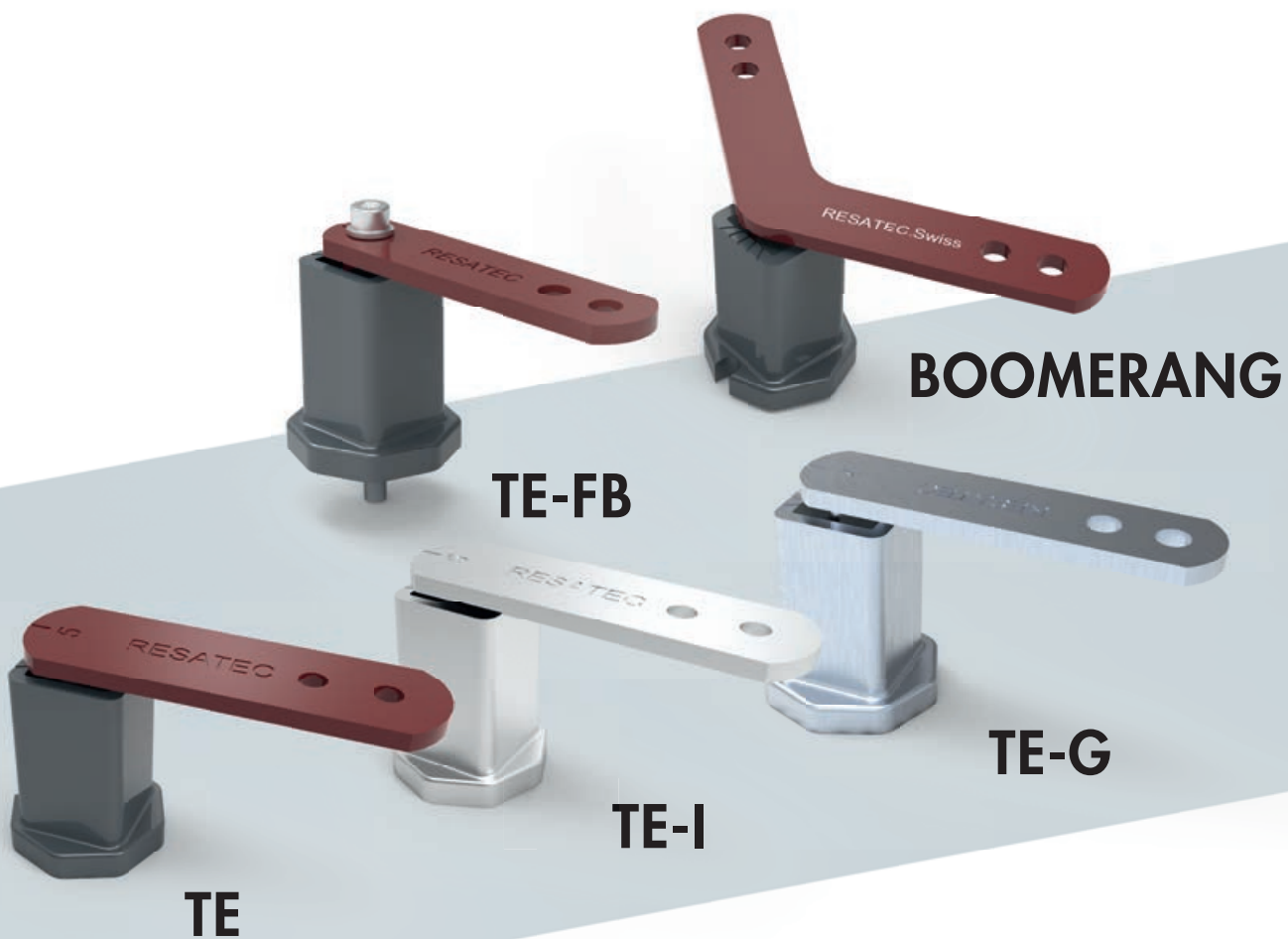



K

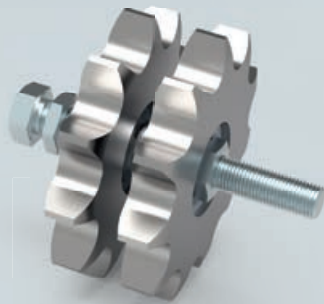

KS-DUPLEX



RE



CRD

SPANNELEMENT TYP TE/TE-G/TE-I

TENSIONER DEVICE TYPE TE/TE-G/TE-I

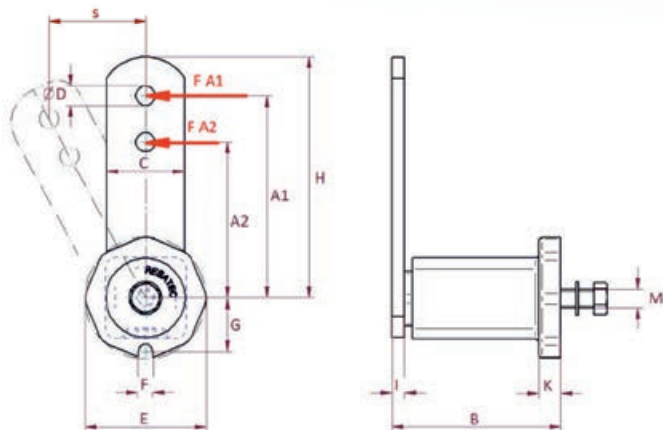

RESATEC SPANNELEMENT TYP TE:

Das Spannelement von RESATEC ist ein Alleskönner, welches andere Spannsysteme bei vielen Anwendungen abgelöst hat. Mit nur einer Schraube wird das Spannelement an der Maschinenstruktur befestigt. Die hohe Qualität der verwendeten Materialien gewährt eine sehr lange Lebensdauer und gleich bleibende Leistungsparameter. Und dies völlig wartungsfrei! Ein sehr widerstandsfähiger Pulverlack schützt vor Korrosion.

RESATEC TENSIONER DEVICE TYPE TE:

The RESATEC tensioning device is an all-rounder that has replaced other tensioning systems in many applications. The tensioning device is fastened to the machine structure with only one screw. The high quality of the materials used ensures a very long service life and consistent performance parameters. And this completely maintenance-free! A very resistant powder coating protects against corrosion.

RESATEC SPANNELEMENT TYP TE-I:

Das Spannelement Typ TE-I wurde für den Einsatz in der chemischen Industrie und im Lebensmittelsektor in rostfreier (INOX) Ausführung hergestellt. Alle technischen Leistungsparameter sind identisch zum Typ TE. Die hohe Qualität gewährt eine sehr lange Lebensdauer, auch unter schwierigen Umweltbedingungen.

RESATEC TENSIONER DEVICE TYPE TE-I:

Tensioner device type TE-I is manufactured in stainless steel (INOX) design for use in chemical industry and food sector. All technical performance parameters are identical to type TE tensioner. The high quality ensures a very long lifetime, even under difficult environmental conditions.

RESATEC SPANNELEMENT TYP TE-G:

Das Spannelement Typ TE-G wurde für den Einsatz in einer anspruchsvollen Umgebung hergestellt. Der Oberflächenschutz durch Galvanisierung erlaubt den Einsatz dort, wo eine Schutzlackierung an Ihre Grenzen stößt, jedoch keine Edelstahl Ausführung gefordert ist. Alle Abmessungen und Einsatzparameter sind unverändert.

RESATEC TENSIONER DEVICE TYPE TE-G:

The tensioner device type TE-G is designed for use in a demanding environment. The surface protection by galvanizing allows the use where a regular protective coating reaches its limits, but no stainless steel design is required. All dimensions and application parameters are unchanged.

Typ type	Art. Nr. art. no.	A1	A2	B	C	øD	E	F	G	H	I	K	M	Material	Schrauben screws		Anzugsmoment tightening torque Nm	Gewicht weight kg				
															TE	Schrauben screws						
TE 2	550 000 02	80	60	52 - 0.5/+1	20	8.5	37.5	8.0	16.6	90	5	6	M6	Gehäuse/housing SINT-C 00	powder coating	Spannarm/tension lever S235JR/S195JR	DIN 933 8.8 ISO 4017 galvanisch verzinkt/galvanized	10	0.2			
TE 3	550 000 03	100	80	63 - 0.5/+1	25	10.5	48	8.5	19.5	115	5	8	M8		galvanized			25	0.36			
TE 3 galv.	550 000 13														powder coating			0.59				
TE 4	550 000 04	100	80	78 - 0.5/+1.5	30	10.5	60	8.5	24.5	115	6	10	M10		galvanized				0.59			
TE 4 galv.	550 000 14														powder coating							
TE 5	550 000 05	130	100	108 - 0.5/+2	50	12.5	78	10.5	34	155	8	14	M12		Gehäuse housing EN-GJS-400-15			powder coating	Spannarm/tension lever S235JR/S195JR	DIN 933 8.8 ISO 4017 galvanisch verzinkt/galvanized	86	1.64
TE 6	550 000 06	175	140	145 - 0.5/+2	60	20.5	100	12.5	42	205	10	15	M16								210	3.33
TE 7	550 000 07	220	175	198 - 1/+3	70	20.5	114	12.5	50	255	12	18	M20								410	6.22
TE 8	550 000 08	250	-	212 - 1/+3	80	20.5	ø130	17	55	290	20	20	M24	750		9.16						

Spannkraft F/tensioning force F

<a	10°		20°		30°		32°	
	FA1 N	s mm	FA1* N	s mm	FA1* N	s mm	FA1* N	s mm
TE								
TE 2/TE-I 2	18	14	43	27	71	40	90	42
TE 3 galv./TE-I 3	28	17	68	34	117	50	140	53
TE 4 galv./TE-I 4	70	17	169	34	303	50	320	53
TE 5/TE-I 5	157	23	380	44	682	65	820	69
TE 6/TE-I 6	278	30	675	60	1 217	88	1 500	93
TE 7/TE-I 7	468	38	1 135	75	2 048	110	2 500	117
TE 8/TE-I 8	479	43	1 162	86	3 255	125	3 900	132

* Die Spannkraft in Pos. FA2 ist ca. 25% grösser
Beachten Sie die Selektions-Hilfen in den folgenden Tabellen:
Kettenradsatz KS-Simplex, Duplex und Triplex
Kettengleiter CR
Spannrollen RE

* The tensioning force in pos. FA2 is approx. 25% higher
Please note the selection aids in the following charts:
Sprocket Wheel-Set KS-Simplex, Duplex and Triplex
Chain rider CR
Roller RE

Typ type	Art. Nr. art. no.	A1	A2	B	C	øD	E	F	G	H	I	K	M	Material	Schrauben screws		Anzugsmoment tightening torque Nm	Gewicht weight kg
															TE-I	Schrauben screws		
TE-I 2	550 000 22	80	60	52 - 0.5/+1	20	8.5	37.5	8.0	16.6	90	5	6	M6	Gehäuse/housing SINT-C 40	Spannarm/tension lever 1.4301	DIN 933 A2-70 ISO 4017	10	0.21
TE-I 3	550 000 33	100	80	63 - 0.5/+1	25	10.5	48	8.5	19.5	115	5	8	M8				25	0.38
TE-I 4	550 000 44	100	80	78 - 0.5/+1.5	30	10.5	60	8.5	24.5	115	6	10	M10				48	0.62
TE-I 5	550 000 55	130	100	108 - 0.5/+2	50	12.5	78	10.5	34.0	155	8	14	M12				82	1.7
TE-I 6	550 000 66	175	135	130 - 0.5/+2	60	20.5	ø-98	12.0	42.0	205	8	15	M16				Gehäuse/housing 1.4301	199

SPANNELEMENT TYP TE-FB/TE-D BOOMERANG

TENSIONER DEVICE TYPE TE-FB/TE-D BOOMERANG



RESATEC-SPANNELEMENT TYP TE-FB:

Das Spannelement Typ TE-FB ist anwendungstechnisch mit den Typen TE, TE-I und TE-G identisch. Der Typ TE-FB kann von vorne mittels Schraube und Spannhülse direkt in an der Maschinenstruktur montiert werden. Dies ermöglicht eine einfache Montage, wenn die Maschinenstruktur von der Rückseite nicht zugänglich ist. Das Spannelement wird durch einen widerstandsfähigen Pulverlack vor Korrosion geschützt.

RESATEC TENSIONER DEVICE TYPE TE-FB:

The tensioner device type TE-FB is identical to the types TE, TE-I and TE-G in terms of application. Type TE-FB can be mounted directly on the machine structure from the front using a screw and clamping sleeve. This allows easy mounting when the machine structure is not accessible from the rear. The tensioner device is protected against corrosion by a resistant powder coating.



RESATEC-SPANNELEMENT TYP TE-D BOOMERANG:

Um bei langen Ketten- und Riementrieben nicht mehrere Elemente zur Kompensation der Längung einsetzen zu müssen, wird der Typ TE-D Boomerang verwendet. Dieser bietet bei gleicher Anwendung mit seinen beiden Auslegern die 3-fache Kompensationslänge des Losetrums mit nur einem Element. Somit wird ein loser Antrieb auch bei Langriemen einfach und zuverlässig verhindert. Das Element wird durch einen widerstandsfähigen Pulverlack vor Korrosion geschützt.

RESATEC TENSIONER DEVICE TYPE TE-D BOOMERANG:

To avoid having to use several elements to compensate for elongation in long chain and belt drives, the type TE-D Boomerang is used. With its two cantilevers, it provides 3 times the compensation of belt elongation for the same application. Thus, a loose drive is easily and reliably prevented even with long belts. The element is protected against corrosion by a resistant powder coating.

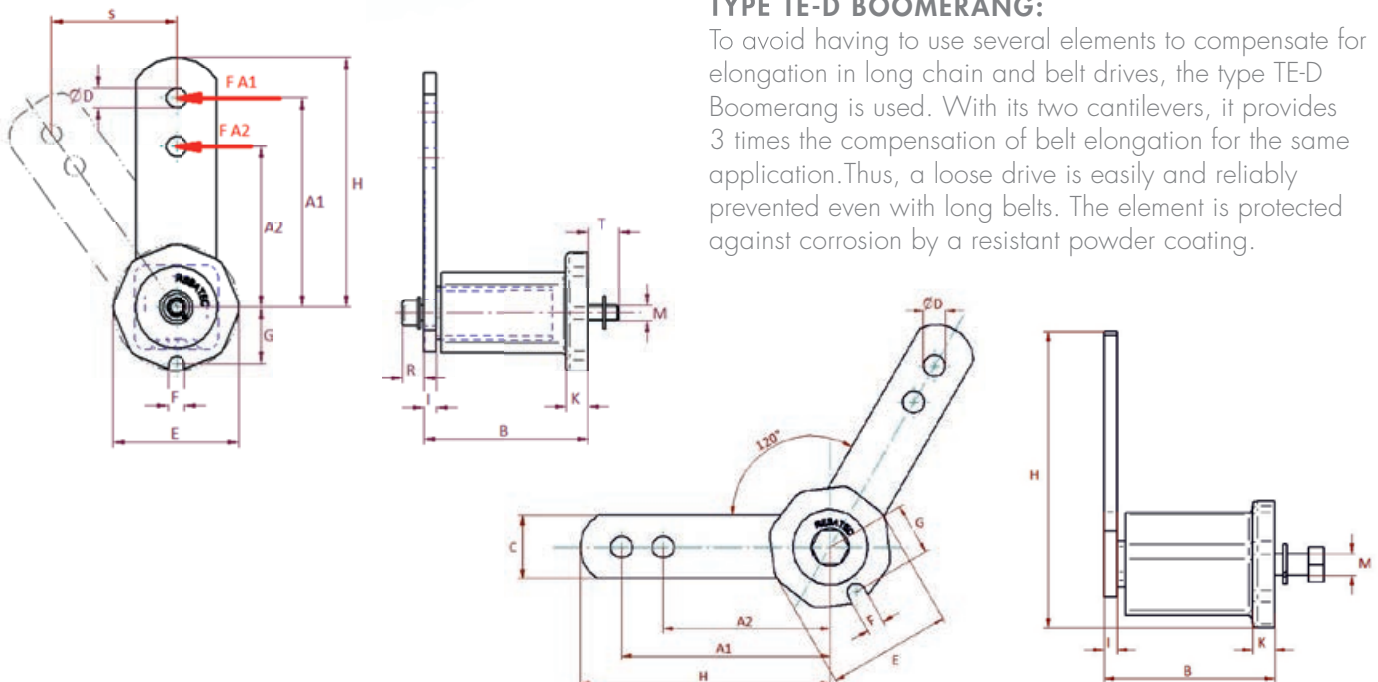

Abmasse/Material/dimensions/material

Typ type	Art. Nr. art. no.	A1	A2	B	C	øD	E	F	G	H	I	K	M	R	S	Material	TE	Anzugsmoment	Gewicht
																		tightening torque	weight
																	Nm	kg	
TE-FB 3	550 003 33	100	80	63 -0.5/+1	25	10.5	48	8.5	19.5	115	5	8	M6	10	13	Gehäuse housing SINTC 00	10	0.46	
TE-FB 4	550 004 44	100	80	78 -0.5/+1.5	30	10.5	60	8.5	24.5	115	6	10	M8	13	17		25	0.65	
TE-FB 5	550 005 55	130	100	108 -0.5/+2	50	12.5	78	10.5	34	155	8	14	M10	15	17		49	1.75	
TE-FB 6	550 006 66	175	140	145 -0.5/+2	60	20.5	100	12.5	42	205	10	15	M12	17	15	Gehäuse housing EN-GJS-400-15	145	3.9	
TE-FB 7	550 007 77	220	175	198 -1/+3	70	20.5	114	12.5	50	255	12	18	M16	23	34	Gehäuse housing S235JR	355	6.8	
TE-FB 8	550 008 08	250	-	212 -1/+3	80	20.5	ø130	17	55	290	20	20	M20	28	38		690	9.3	

Material

Pulverlackierung
Spannarm S235JR/S195JR
Schrauben: Spannhülse galvanisch verzinkt
DIN 933 8.8 ISO 4017 TE-FB 3 – TE-FB 5
DIN 933 12.9 ISO 4017 TE-FB 6 – TE-FB 8

Material

powder coating
tension lever S235JR/S195JR
screws: Spacer sleeve galvanized
DIN 933 8.8 ISO 4017 TE-FB 3 – TE-FB 5
DIN 933 12.9 ISO 4017 TE-FB 6 – TE-FB 8

Spannkraft F/tensioning force F

α	10°		20°		30°		32°	
	FA1 N	s mm	FA1 N	s mm	FA1 N	s mm	FA1 N	s mm
TE-FB								
TE-FB 3	28	17	68	34	117	50	140	53
TE-FB 4/TE-D – 4S	70	17	169	34	303	50	320	53
TE-FB 5/TE-D – 5S	157	23	380	44	682	65	820	69
TE-FB 6	278	30	675	60	1 217	88	1 500	93
TE-FB 7	468	38	1 135	75	2 048	110	2 500	117

Beachten Sie die Selektions-Hilfen
in den folgenden Tabellen:
Kettenradsatz KS-Simplex,
Duplex und Triplex
Kettengleiter CR
Spannrollen RE

Please note the selection aids in the
following charts:
Sprocket Wheel-Set KS-Simplex, Duplex and Triplex
Chain rider CR
Roller RE

Abmasse/Material/dimensions/material

Typ type	Art. Nr. art. no.	A1	A2	B	C	øD	E	F	G	H	I	K	M	R	S	F [N] @ 32°		Anzugsmoment	Gewicht
																A1	A2		
TE-D – 4S	550 000 44 3	100	80	78	30	10.5	56	8.5	24.8	135	6	10	M10	10	13	0 – 320	0 – 430	10	0.46
TE-D – 5S	550 000 55 3	130	100	108	50	12.5	73.7	9.8	34.5	189	8	14	M12	13	17	0 – 820	0 – 1 050	25	0.65

Material

Pulverlackierung
Gehäuse SINTC 00
Spannarm S235JR/S195JR
Schrauben: DIN 933 8.8 ISO 4017 verzinkt

Material

powder coating
housing SINTC 00
tension lever S235JR/S195JR
screws: DIN 933 8.8 ISO 4017 galvanized

SPANNROLLE TYP RE

ROLLER TYPE RE



RESATEC SPANNROLLE TYP RE:

Zu Beginn als rotierende Rolle zum Spannen von Flachriemen und später zum Spannen von Poly- und V-Riemen sowie Kraftbänder entwickelt, wird die Spannrolle Typ RE vielfach als universelle Maschinenkomponente eingesetzt. Möchten Sie Anpassungen im Material, Durchmesser oder Form? Bitte klären Sie die Möglichkeiten mit uns ab.

RESATEC ROLLER TYPE RE:

Initially developed as a rotating pulley for tensioning flat belts and later for tensioning poly and V-belts as well as power belts, the roller type RE is widely used as a universal machine component. Would you like adaptations in material, diameter or shape? Please clarify the possibilities with us.



RESATEC-SPANNSICHERUNG TYP TL:

Liegt an der Montagefläche eine Beschichtung oder Unebenheit vor, welche einen sicheren Reibschluss verhindert, empfiehlt sich die Verwendung der RESATEC-Spannsicherung. Verfügbar für alle Spannelemente-Typen der Grösse 5 und 6.

RESATEC TWIST LOCK TYPE TL:

If there is a coating or unevenness on the mounting surface that prevents a secure friction locking, it is recommended to use the RESATEC twist lock. Available for all tensioner devices of size 5 and 6.

**PASSEND ZU ALLEN TE-TYPEN
SEITE 42/44**



**MATCHING ALL
TE-TYPES
PAGE 42/44**

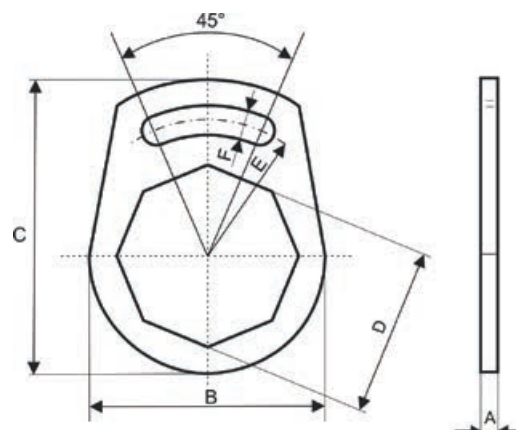
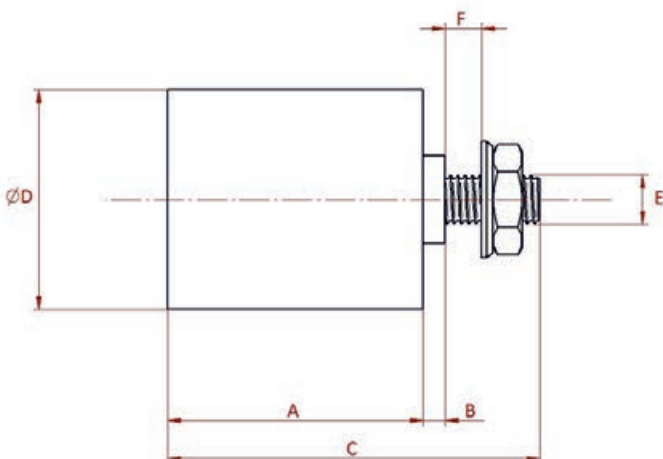

Typ type	Art. Nr. art. no.	øD	A	E	6kt-Mutter hex-nut	Anziehmoment tightening torque				Kugellager ball bearing	min ⁻¹ rpm max.	passend zu suitable for	Gewicht weight	max. Belastung max. load
						Nm	B	C	F					
RE 2	552 002 00	30	35	M8	M8 – 0.5d	10	3	51	7	608–2Z	8000	TE 2	0.08	75
RE 3/4	552 003 00	40	45	M10	M10 – 0.5d	20	6	67	9	6200–2Z	8000	TE 3/TE 4	0.17	160
RE 5	552 005 00	60	60	M12	M12 – 0.5d	35	7.5	89	13	6301–2Z	6000	TE 5	0.4	310
RE 6	552 006 00	80	90	M20	M20 – 0.5d	160	9	127	14	6304–2Z	5000	TE 6/TE 7	1.2	610
RE 7	552 007 00	80	135	M20	M20 – 0.5d	160	7	167	12	6304–2Z	4500	TE 7	1.7	1210
TL 5	580 001 05	74.5	8	60				104	130			TE 5	0.12	
TL 6	580 001 06	94	10	75				128	160			TE 6	0.23	

Rolle PA6

Temperaturbereich –40°C bis 100°C

Schraube DIN 933 ISO 4017 Stahl 8,8 galvanisch verzinkt

6kt-Mutter DIN 439 B ISO 4035 Stahl 8,8 galvanisch verzinkt

In Ex-Schutzräumen empfehlen wir die Komponenten zu erden

Oberflächenwiderstand ~1013 Ohm, Durchgangswiderstand ~1015 Ohm

Roller PA6

temperature range –40°C until 100°C

screw DIN 933 ISO 4017 steel 8.8 galvanised

hex-nut DIN 439 B ISO 4035 steel 8.8 galvanised

in Ex-shelters the components have to be to grounded

surface resistance ~1013 ohm, contact resistance ~1015 ohm

Auswahltabelle für TE + Rolle RE/Selection schedule for TE + Rollers RE

Keilriemenprofil V-belt Type	ø kleinere Scheibe ø smaller pulley	Spannkraft [N] tensioning force [N]	Typ Spannelement type tensioner device	Spannkraft [N] tensioning force [N]	Typ Spannelement type tensioner device	Spannkraft [N] tensioning force [N]	Typ Spannelement type tensioner device	Spannkraft [N] tensioning force [N]	Typ Spannelement type tensioner device	Spannkraft [N] tensioning force [N]	Typ Spannelement type tensioner device	1 Riemen/1 belt		2 Riemen/2 belts		3 Riemen/3 belts		4 Riemen/4 belts		5 Riemen/5 belts			
												Spannkraft [N]	Typ Spannelement	Spannkraft [N]	Typ Spannelement	Spannkraft [N]	Typ Spannelement	Spannkraft [N]	Typ Spannelement	Spannkraft [N]	Typ Spannelement	Spannkraft [N]	Typ Spannelement
XPZ, SPZ	56 – 71	40	TE 2 + RE 2	80	TE 4 + RE 3/4	120	TE 4 + RE 3/4	160	TE 5 + RE 5	200	TE 5 + RE 5	56 – 71	40	TE 2 + RE 2	80	TE 4 + RE 3/4	120	TE 4 + RE 3/4	160	TE 5 + RE 5	200	TE 5 + RE 5	
	75 – 90	44	TE 2 + RE 2	88	TE 4 + RE 3/4	132	TE 4 + RE 3/4	176	TE 5 + RE 5	220	TE 5 + RE 5	75 – 90	44	TE 2 + RE 2	88	TE 4 + RE 3/4	132	TE 4 + RE 3/4	176	TE 5 + RE 5	220	TE 5 + RE 5	
	95 – 125	50	TE 3 + RE 3/4	100	TE 4 + RE 3/4	150	TE 4 + RE 3/4	200	TE 5 + RE 5	250	TE 5 + RE 5	95 – 125	50	TE 3 + RE 3/4	100	TE 4 + RE 3/4	150	TE 4 + RE 3/4	200	TE 5 + RE 5	250	TE 5 + RE 5	
	>125	56	TE 3 + RE 3/4	112	TE 4 + RE 3/4	168	TE 4 + RE 3/4	224	TE 5 + RE 5	280	TE 5 + RE 5	>125	56	TE 3 + RE 3/4	112	TE 4 + RE 3/4	168	TE 4 + RE 3/4	224	TE 5 + RE 5	280	TE 5 + RE 5	
XPA, SPA	80 – 100	56	TE 3 + RE 3/4	112	TE 4 + RE 3/4	168	TE 5 + RE 5	224	TE 5 + RE 5	280	TE 6 + RE 6	80 – 100	56	TE 3 + RE 3/4	112	TE 4 + RE 3/4	168	TE 5 + RE 5	224	TE 5 + RE 5	280	TE 6 + RE 6	
	106 – 140	76	TE 4 + RE 3/4	152	TE 4 + RE 3/4	228	TE 5 + RE 5	304	TE 5 + RE 5	380	TE 6 + RE 6	106 – 140	76	TE 4 + RE 3/4	152	TE 4 + RE 3/4	228	TE 5 + RE 5	304	TE 5 + RE 5	380	TE 6 + RE 6	
	150 – 200	90	TE 4 + RE 3/4	180	TE 4 + RE 3/4	270	TE 5 + RE 5	360	TE 5 + RE 5	450	TE 6 + RE 6	150 – 200	90	TE 4 + RE 3/4	180	TE 4 + RE 3/4	270	TE 5 + RE 5	360	TE 5 + RE 5	450	TE 6 + RE 6	
	>200	100	TE 4 + RE 3/4	200	TE 4 + RE 3/4	300	TE 5 + RE 5	400	TE 6 + RE 6	500	TE 6 + RE 6	>200	100	TE 4 + RE 3/4	200	TE 4 + RE 3/4	300	TE 5 + RE 5	400	TE 6 + RE 6	500	TE 6 + RE 6	
XPB, SPB	112 – 160	100	TE 4 + RE 3/4	200	TE 4 + RE 3/4	300	TE 5 + RE 5	400	TE 6 + RE 6	500	TE 7 + RE 7	112 – 160	100	TE 4 + RE 3/4	200	TE 4 + RE 3/4	300	TE 5 + RE 5	400	TE 6 + RE 6	500	TE 7 + RE 7	
	170 – 224	124	TE 4 + RE 3/4	248	TE 5 + RE 5	372	TE 5 + RE 5	496	TE 6 + RE 6	620	TE 7 + RE 7	170 – 224	124	TE 4 + RE 3/4	248	TE 5 + RE 5	372	TE 5 + RE 5	496	TE 6 + RE 6	620	TE 7 + RE 7	
	236 – 355	154	TE 4 + RE 3/4	308	TE 5 + RE 5	462	TE 6 + RE 6	616	TE 6 + RE 6	770	TE 7 + RE 7	236 – 355	154	TE 4 + RE 3/4	308	TE 5 + RE 5	462	TE 6 + RE 6	616	TE 6 + RE 6	770	TE 7 + RE 7	
	>355	162	TE 4 + RE 3/4	324	TE 5 + RE 5	486	TE 6 + RE 6	648	TE 6 + RE 6	810	TE 7 + RE 7	>355	162	TE 4 + RE 3/4	324	TE 5 + RE 5	486	TE 6 + RE 6	648	TE 6 + RE 6	810	TE 7 + RE 7	
XPC, SPC	224 – 250	174	TE 4 + RE 3/4	348	TE 5 + RE 5	522	TE 6 + RE 6	696	TE 7 + RE 7	870	TE 7 + RE 7	224 – 250	174	TE 4 + RE 3/4	348	TE 5 + RE 5	522	TE 6 + RE 6	696	TE 7 + RE 7	870	TE 7 + RE 7	
	265 – 355	230	TE 5 + RE 5	460	TE 6 + RE 6	690	TE 6 + RE 6	920	TE 7 + RE 7	1150	TE 7 + RE 7	265 – 355	230	TE 5 + RE 5	460	TE 6 + RE 6	690	TE 6 + RE 6	920	TE 7 + RE 7	1150	TE 7 + RE 7	
	>375	288	TE 5 + RE 5	576	TE 6 + RE 6	864	TE 7 + RE 7	1152	TE 7 + RE 7	1440	TE 7 + RE 7	>375	288	TE 5 + RE 5	576	TE 6 + RE 6	864	TE 7 + RE 7	1152	TE 7 + RE 7	1440	TE 7 + RE 7	
Z	56 – 100	15	TE 2 + RE 2	30	TE 2 + RE 2	45	TE 2 + RE 2	60	TE 3 + RE 3/4	75	TE 5 + RE 5	Z	56 – 100	15	TE 2 + RE 2	30	TE 2 + RE 2	45	TE 2 + RE 2	60	TE 3 + RE 3/4	75	TE 5 + RE 5
A	80 – 140	30	TE 2 + RE 2	60	TE 3 + RE 3/4	90	TE 4 + RE 3/4	120	TE 5 + RE 5	150	TE 6 + RE 6	A	80 – 140	30	TE 2 + RE 2	60	TE 3 + RE 3/4	90	TE 4 + RE 3/4	120	TE 5 + RE 5	150	TE 6 + RE 6
B	125 – 200	60	TE 3 + RE 3/4	120	TE 4 + RE 3/4	180	TE 5 + RE 5	240	TE 6 + RE 6	300	TE 7 + RE 7	B	125 – 200	60	TE 3 + RE 3/4	120	TE 4 + RE 3/4	180	TE 5 + RE 5	240	TE 6 + RE 6	300	TE 7 + RE 7
C	200 – 400	120	TE 4 + RE 3/4	240	TE 5 + RE 5	360	TE 6 + RE 6	480	TE 7 + RE 7	600	TE 7 + RE 7	C	200 – 400	120	TE 4 + RE 3/4	240	TE 5 + RE 5	360	TE 6 + RE 6	480	TE 7 + RE 7	600	TE 7 + RE 7
D	335 – 600	210	TE 4 + RE 3/4	420	TE 6 + RE 6	630	TE 7 + RE 7	840	TE 7 + RE 7	1050	TE 7	D	335 – 600	210	TE 4 + RE 3/4	420	TE 6 + RE 6	630	TE 7 + RE 7	840	TE 7 + RE 7	1050	TE 7

KETTENGLEITER TYP CR/CRS/CRD

CHAIN RIDER TYPE CR/CRS/CRD

CR



CRS



CRD



RESATEC KETTENGLEITER TYP CR/CRS/CRD:

Für die Spannung von Ketten mit geringer Laufgeschwindigkeit (Dauerbetrieb bis 1,5 m/s) kann der Kettengleiter Typ CR eingesetzt werden. Der hochwertige Kunststoff kommt ohne jegliche Schmierung aus. Durch die einzigartige Formgebung umschließt die Kette den Gleiter immer so, dass eine problemlose Führung der Kette gewährleistet wird. Typ CRS bzw. CRD wird als Set mit dem passenden Befestigungsmaterial zum entsprechenden Spannelement mitgeliefert.

RESATEC CHAIN RIDER TYPE CR/CRS/CRD:

For the tensioning of chains with low running speed (continuous operation up to 1.5 m/s) the chain rider type CR can be used. The high quality plastic material does not require any lubrication. Due to the unique design, the chain always encloses the rider in such a way that problem-free guiding of the chain is ensured. Type CRS or CRD is supplied as a set with the appropriate assembly material for the corresponding tensioning element.

**PASSEND ZU ALLEN TE-TYPEN
SEITE 42/44**



**MATCHING ALL
TE-TYPES
PAGE 42/44**

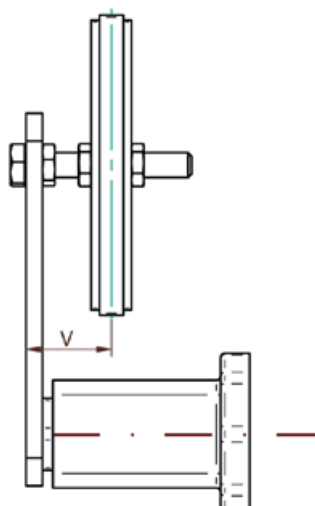
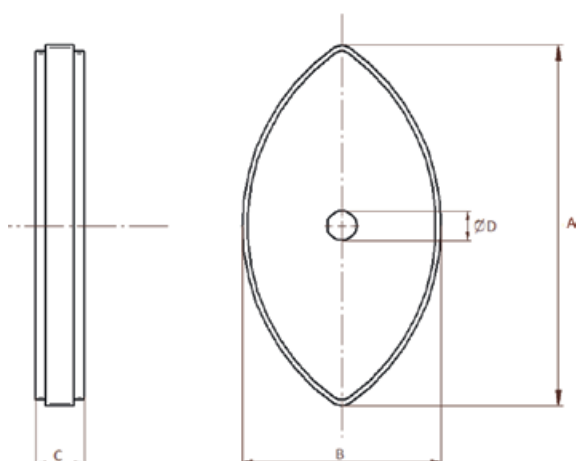

Typ type	Art. Nr. art. no.	Rollenkette roller chain	ANSI					Schraube screw	6kt-Mutter hex-nut 3Stk/pcs	Anzieh- moment torque	passend zu suitable for	Einstellbereich adjusting range	Gewicht weight
			C	A	B	øD	V						
		DIN 8187							Nm	Typ/type		kg	
CR 3/8" -8	553 000 10	ISO-06 B	35	10.2	74	40	8	–	–	–	–	–	0.02
CR 1/2" -10	553 000 11	ISO-08 B	40	13.9	96	50	10	–	–	–	–	–	0.05
CR 5/8" -10	553 000 12	ISO-10 B	50	16.5	125	55	10	–	–	–	–	–	0.08
CR 3/4" -12	553 000 13	ISO-12 B	60	19.5	147	80	12	–	–	–	–	–	0.12
CRS 3/8" S	553 001 10	ISO-06 B-1	35	10.2	74	40	–	M8×45	M8 – 0.5d	10	TE 3	21 – 34	0.05
CRS 1/2" S	553 001 11	ISO-08 B-1	40	13.9	96	50	–	M10×60	M10 – 0.5d	20	TE 3/TE 4	23 – 47/24 – 47	0.11
CRS 5/8" S	553 001 12	ISO-10 B-1	50	16.5	125	55	–	M10×60	M10 – 0.5d	20	TE 4	25 – 48	0.14
CRS 3/4" S	553 001 13	ISO-12 B-1	60	19.5	147	80	–	M12×80	M12 – 0.5d	35	TE 5	29 – 64	0.22
CRS 3/8" D	553 002 10	ISO-06 B-2	35	10.2	74	40	–	M8×45	M8 – 0.5d	10	TE 3	26 – 29	0.07
CRS 1/2" D	553 002 11	ISO-08 B-2	40	13.9	96	50	–	M10×60	M10 – 0.5d	20	TE 3/TE 4	30 – 40/31 – 40	0.12
CRS 5/8" D	553 002 12	ISO-10 B-2	50	16.5	125	55	–	M10×60	M10 – 0.5d	20	TE 4	34 – 47	0.17
CRS 3/4" D	553 002 13	ISO-12 B-2	60	19.5	147	80	–	M12×80	M12 – 0.5d	35	TE 5	39 – 54	0.26
CRS-I 3/8" S	553 101 10	ISO-06 B-1	35	10.2	74	40	–	M8×45	M8 – 0.5d	10	TE-I 3	21 – 34	0.05
CRS-I 1/2" S	553 101 11	ISO-08 B-1	40	13.9	96	50	–	M10×60	M10 – 0.5d	20	TE-I 3/TE-I 4	23 – 47/24 – 47	0.11
CRS-I 5/8" S	553 101 12	ISO-10 B-1	50	16.5	125	55	–	M10×60	M10 – 0.5d	20	TE-I 4	25 – 48	0.14
CRS-I 3/4" S	553 101 13	ISO-12 B-1	60	19.5	147	80	–	M12×80	M12 – 0.5d	35	TE-I 5	29 – 64	0.22
CRS-I 3/8" D	553 102 10	ISO-06 B-2	35	10.2	74	40	–	M8×45	M8 – 0.5d	10	TE-I 3	26 – 29	0.07
CRS-I 1/2" D	553 102 11	ISO-08 B-2	40	13.9	96	50	–	M10×60	M10 – 0.5d	20	TE-I 3/TE-I 4	30 – 40/31 – 40	0.12
CRS-I 5/8" D	553 102 12	ISO-10 B-2	50	16.5	125	55	–	M10×70	M10 – 0.5d	20	TE-I 4	34 – 47	0.17
CRS-I 3/4" D	553 102 13	ISO-12 B-2	60	19.5	147	80	–	M12×80	M12 – 0.5d	35	TE-I 5	39 – 54	0.26

Material

Gleiter CR aus Vesconite®

Temperaturbereich –40°C bis 120°C

max. Reibungswärme 240°C

max. Kettengeschwindigkeit 1,5 m/s

Schraube DIN 933 ISO 4017 Stahl 8,8 galvanisch verzinkt

CRS-I Schraube DIN 933 ISO 4017 A2

6kt-Mutter DIN 439 B ISO 4035 Stahl 8,8 galvanisch verzinkt

CRS-I 6kt-Mutter DIN 439 B ISO 4035 A2

In Ex-Schutzräumen empfehlen wir die Komponenten zu erden

Typ CRS S verpackt mit Heissfolie auf Karton

andere Typen lose verpackt

Material

Glider CR made in Vesconite®

temperature range –40°C until 120°C

max. frictional head 240°C

max. chain speed limit 1.5 m/s

screw DIN 933 ISO 4017 steel 8.8 galvanised

CRS-I screw DIN 933 ISO 4017 A2

hex-nut DIN 439 B ISO 4035 steel 8.8 galvanised

CRS-I hex-nut DIN 439 B ISO 4035 A2

in Ex-shelters the components have to be grounded

type CRS S are skinpacked on cardboard

the other types components are loosely packed

KETTENRAD TYP K/KS SIMPLEX

SPROCKET WHEEL TYPE K/KS SIMPLEX

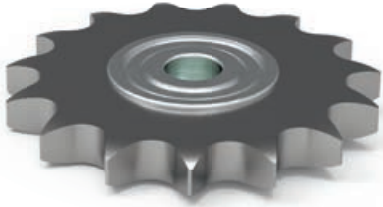

K



KS-SIMPLEX

RESATEC KETTENRAD TYP K:

Für die Spannung von Ketten bietet RESATEC AG ein auf die RESATEC-Spannelemente abgestimmtes Programm von Kettenrädern an.

RESATEC SPROCKET TYPE K:

For the tensioning of chains, RESATEC AG offers a range of sprocket wheels matching the RESATEC tensioner devices.

RESATEC KETTENRAD-SATZ TYP KS-SIMPLEX:

Verpackt im Set Typ KS-Simplex wird mit dem Kettenrad das passende Befestigungsmaterial zum entsprechenden RESATEC Spannelement mitgeliefert.

RESATEC SPROCKET SET TYPE KS-SIMPLEX:

Packed in the set type KS-Simplex, the sprocket wheel is supplied with the appropriate assembly material for the corresponding RESATEC tensioner device.

**PASSEND ZU ALLEN TE-TYPEN
SEITE 42/44**



**MATCHING ALL
TE-TYPES
PAGE 42/44**

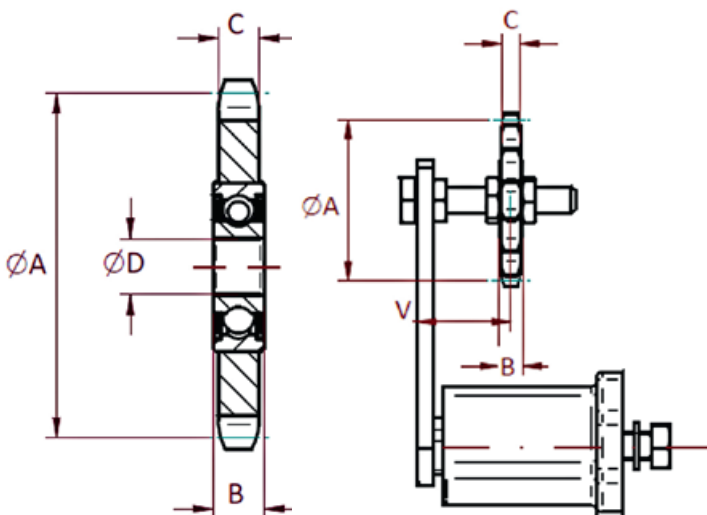

Abmasse/Material/dimensions/material

Typ type	Art. Nr. art. no.	Rollenkette roller chain		C	Anz. Zähne no. of teeth		øA	B	øD	Kugellager ball bearing	6kt-Mutter hex-nut 3Stk/pcs	Gewicht weight
		DIN 8187	ANSI		Mm							
K 3/8"-10	551 020 09	ISO-06 B	35	5.7	15	45.81	9	10	6 200-2Z	-	0.02	
K 1/2"-10	551 030 09	ISO-08 B	40	7.2	15	61.08	9	10	6 200-2Z	-	0.05	
K 1/2"-12	551 040 09	ISO-08 B	40	7.2	15	61.08	12	12	6 301-2Z	-	0.08	
K 5/8"-12	551 050 09	ISO-10 B	50	9.1	15	76.36	12	12	6 301-2Z	-	0.12	
K 5/8"-20	551 060 09	ISO-10 B	50	9.1	15	76.36	15	20	6 304-2Z	M8 - 0.5d	0.05	
K 3/4"-12	551 070 09	ISO-12 B	60	11.5	15	91.63	12	12	6 301-2Z	M10 - 0.5d	0.11	
K 3/4"-20	551 080 09	ISO-12 B	60	11.5	15	91.63	15	20.0	6 301-2Z	M10 - 0.5d	0.14	
K 1"-20	551 090 09	ISO-16 B	80	16.2	13	106.14	15	20	6 304-2Z	M12 - 0.5d	0.22	
K 1 1/4"-20	551 100 09	ISO-20 B	100	18.5	13	132.67	15	20	6 304-2Z	M8 - 0.5d	0.07	
K 1 1/2"-20	551 110 09	ISO-24 B	120	24.1	11	135.23	15	20	6 304-2Z	M10 - 0.5d	0.12	

Material

Kettenräder DIN 1.0503 galvanisch verzinkt
 Zähne induktionsgehärtet HRC 50
 Zähneform ISO 606
 Temperaturbereich -40°C bis 120°C
 lose verpackt

Material

sprockets DIN 1.0503 galvanised
 teeth induction hardness HRC 50
 tooth shape according ISO 606
 temperature range -40°C until 120°C
 sprockets are loosely packed

Abmasse/Material/dimensions/material

Typ type	Art. Nr. art. no.	Rollenkette roller chain		C	Anz. Zähne no. of teeth		øA	B	Schraube screw	6kt-Mutter hex-nut 3Stk/pcs	Anzieh- moment torque	Kugellager ball bearing	passend zu suitable for	Einstellbereich adjusting range	Gewicht weight
		DIN 8187	ANSI												
KS 3/8"-10 S	551 020 00	ISO-06 B-1	35	5.7	15	45.81	9	M10×60	M10 - 0.5d	20	6 200-2Z	TE 3/TE 4	21 - 50	0.15	
KS 1/2"-10 S	551 030 00	ISO-08 B-1	40	7.2	15	61.08	9	M10×60	M10 - 0.5d	20	6 200-2Z	TE 4	21 - 50	0.2	
KS 1/2"-12 S	551 040 00	ISO-08 B-1	40	7.2	15	61.08	12	M12×80	M12 - 0.5d	35	6 301-2Z	TE 5	27 - 67	0.23	
KS 5/8"-12 S	551 050 00	ISO-10 B-1	50	9.1	15	76.36	12	M12×80	M12 - 0.5d	35	6 301-2Z	TE 5	27 - 67	0.7	
KS 5/8"-20 S	551 060 00	ISO-10 B-1	50	9.1	15	76.36	15	M20×120	M20 - 0.5d	160	6 304-2Z	TE 6	38 - 101	0.7	
KS 3/4"-12 S	551 070 00	ISO-12 B-1	60	11.5	15	91.63	12	M12×80	M12 - 0.5d	35	6 301-2Z	TE 5	27 - 67	0.6	
KS 3/4"-20 S	551 080 00	ISO-12 B-1	60	11.5	15	91.63	15	M20×120	M20 - 0.5d	160	6 304-2Z	TE 6	38 - 101	0.9	
KS 1"-20 S	551 090 00	ISO-16 B-1	80	16.2	13	106.14	15	M20×120	M20 - 0.5d	160	6 304-2Z	TE 6	38 - 101	1.3	
KS 1 1/4"-20 S	551 100 00	ISO-20 B-1	100	18.5	13	132.67	15	M20×140	M20 - 0.5d	160	6 304-2Z	TE 7/TE 8	41 - 121/ 49 - 121	2.05	
KS 1 1/2"-20 S	551 110 00	ISO-24 B-1	120	24.1	11	135.23	15	M20×140	M20 - 0.5d	160	6 304-2Z	TE 7/TE 8	41 - 121/ 49 - 121	2.4	

Material

Kettenräder DIN 1.0503 galvanisch verzinkt
 Zähne induktionsgehärtet HRC 50
 Zähneform ISO 606
 Temperaturbereich -40°C bis 120°C
 Schraube DIN 933 ISO 4017 Stahl 8,8 galvanisch verzinkt
 6kt-Mutter DIN 439 B ISO 4035 Stahl 8,8 galvanisch verzinkt
 verpackt mit Heissfolie auf Karton

Material

sprockets DIN 1.0503 galvanised
 teeth induction hardness HRC 50
 tooth shape according ISO 606
 temperature range -40°C until 120°C
 srew DIN 933 ISO 4017 steel 8.8 galvanised
 hex-nut DIN 439 B ISO 4035 steel 8.8 galvanised
 set skinpacked on cardboard

KETTENRADSATZ TYP KS DUPLEX/-TRIPLEX

SPROCKET WHEEL SET TYPE KS DUPLEX/-TRIPLEX

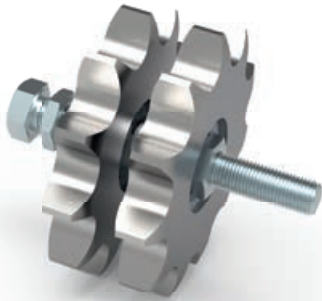

RESATEC KETTENRAD-SATZ TYP KS-DUPLEX/-TRIPLEX:

Für das Spannen von weiteren Ketten liefern wir den Kettenrad-Satz Typ KS-Duplex mit zwei Kettenräder und den Kettenrad-Satz Typ KS-Triplex mit drei Kettenräder inklusive den entsprechenden Distanzbüchsen zur korrekten Führung der Kettenspur.

RESATEC SPROCKET SET TYPE KS-DUPLEX/-TRIPLEX:

For the tensioning of additional chains, we supply the sprocket set type KS-Duplex with two sprockets and the sprocket set type KS-Triplex with three sprockets including the corresponding spacer sleeves for the correct guidance of the chain track.



**PASSEND ZU ALLEN TE-TYPEN
SEITE 42/44**



**MATCHING ALL
TE-TYPES
PAGE 42/44**

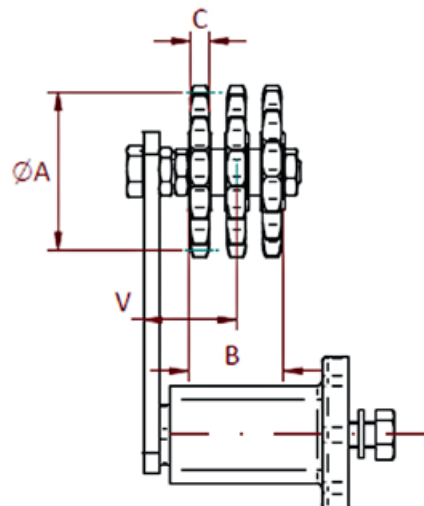
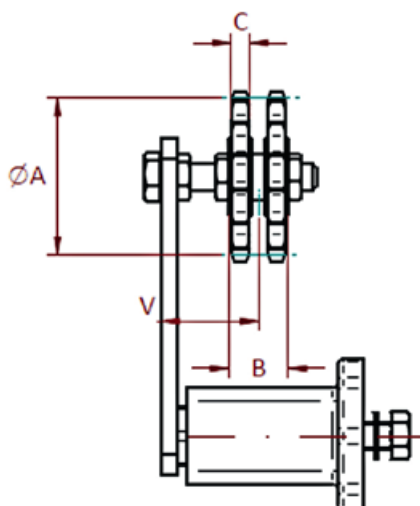

Abmasse/Material/dimensions/material

Typ type	Art. Nr. art. no.	Rollenkette roller chain	C		Anz. Zähne no. of teeth	øA	B	Schraube screw	6kt-Mutter hex-nut 3Stk/pcs	Anzieh- moment torque	Kugellager ball bearing	passend zu suitable for	Einstellbereich adjusting range	Gewicht weight
			DIN 8187	ANSI										
KS 3/8"–10 D	551 020 20	ISO–06 B-2	35	5.7	15	45.81	19.2	M10×60	M10–0.5d	20	6 200–2Z	TE 3/TE 4	26–44	0.2
KS 1/2"–10 D	551 030 20	ISO–08 B-2	40	7.2	15	61.08	22.9	M10×60	M10–0.5d	20	6 200–2Z	TE 4	28–42	0.35
KS 1/2"–12 D	551 040 20	ISO–08 B-2	40	7.2	15	61.08	26	M12×80	M12–0.5d	35	6 301–2Z	TE 5	34–60	0.45
KS 5/8"–12 D	551 050 20	ISO–10 B-2	50	9.1	15	76.36	28.6	M12×80	M12–0.5d	35	6 301–2Z	TE 5	35–59	0.6
KS 5/8"–20 D	551 060 20	ISO–10 B-2	50	9.1	15	76.36	31.5	M20×120	M20–0.5d	160	6 304–2Z	TE 6	47–93	1
KS 3/4"–12 D	551 070 20	ISO–12 B-2	60	11.5	15	91.63	31.5	M12×80	M12–0.5d	35	6 301–2Z	TE 5	37–57	1.05
KS 3/4"–20 D	551 080 20	ISO–12 B-2	60	11.5	15	91.63	34.5	M20×120	M20–0.5d	160	6 304–2Z	TE 6	38–101	1.35
KS 1"–20 D	551 090 20	ISO–16 B-2	80	16.2	13	106.14	46.9	M20×120	M20–0.5d	160	6 304–2Z	TE 6	48–92	2.1
KS 1 1/4"–20 D	551 100 20	ISO–20 B-2	100	18.5	13	132.67	51.5	M20×140	M20–0.5d	160	6 304–2Z	TE 7/TE 8	59–103/ 67–103	3.6
KS 1 1/2"–20 D	551 110 20	ISO–24 B-2	120	24.1	11	135.23	63.4	M20×140	M20–0.5d	160	6 304–2Z	TE 7/TE 8	65–97/ 73–97	4.25

Material

Kettenräder DIN 1.0503 galvanisch verzinkt
 Zähne induktionsgehärtet HRC 50
 Zähneform ISO 606
 Temperaturbereich –40°C bis 120°C
 Schraube DIN 933 ISO 4017 Stahl 8,8 galvanisch verzinkt
 6kt-Mutter DIN 439 B ISO 4035 Stahl 8,8 galvanisch verzinkt
 Komponenten lose verpackt

Material

sprockets DIN 1.0503 galvanised
 teeth induction hardness HRC 50
 tooth shape according ISO 606
 temperature range –40°C until 120°C
 screw DIN 933 ISO 4017 steel 8.8 galvanised
 hex-nut DIN 439 B ISO 4035 steel 8.8 galvanised
 components are loosely packed

Abmasse/Material/dimensions/material

Typ type	Art. Nr. art. no.	Rollenkette roller chain	C		Anz. Zähne no. of teeth	øA	B	Schraube screw	6kt-Mutter hex-nut 3Stk/pcs	Anzieh- moment torque	Kugellager ball bearing	passend zu suitable for	Einstell- bereich adjusting range	Gewicht weight
			DIN 8187	ANSI										
KS 3/8"–10 T	551 020 30	ISO–06 B-3	35	5.7	15	45.81	29.4	M10×60	M10–0.5d	20	6 200–2Z	TE 4	32–39	0.25
KS 1/2"–12 T	551 040 30	ISO–08 B-3	40	7.2	15	61.08	40	M12×80	M12–0.5d	35	6 301–2Z	TE 5	41–53	0.5
KS 5/8"–12 T	551 050 30	ISO–10 B-3	50	9.1	15	76.36	45.2	M12×80	M12–0.5d	35	6 301–2Z	TE 5	43–51	0.95
KS 5/8"–20 T	551 060 30	ISO–10 B-3	50	9.1	15	76.36	48.2	M20×120	M20–0.5d	160	6 304–2Z	TE 6	55–85	1.25
KS 3/4"–20 T	551 080 30	ISO–12 B-3	60	11.5	15	91.63	54	M20×120	M20–0.5d	160	6 304–2Z	TE 6	58–82	1.5
KS 1"–20 T	551 090 30	ISO–16 B-3	80	16.2	13	106.14	78.8	M20×160	M20–0.5d	160	6 304–2Z	TE 7	72–110	2.9
KS 1 1/4"–20 T	551 100 30	ISO–20 B-3	100	18.5	13	132.67	88	M20×160	M20–0.5d	160	6 304–2Z	TE 7/TE 8	77–105/ 85–105	5.2
KS 1 1/2"–20 T	551 110 30	ISO–24 B-3	120	24.1	11	135.23	111.8	M20×180	M20–0.5d	160	6 304–2Z	TE 7/TE 8	89–113/ 97–113	6.2

Material

Kettenräder DIN 1.0503 galvanisch verzinkt
 Zähne induktionsgehärtet HRC 50
 Zähneform ISO 606
 Temperaturbereich –40°C bis 120°C
 Schraube DIN 933 ISO 4017 Stahl 8,8 galvanisch verzinkt
 6kt-Mutter DIN 439 B ISO 4035 Stahl 8,8 galvanisch verzinkt
 Komponenten lose verpackt

Material

sprockets DIN 1.0503 galvanised
 teeth induction hardness HRC 50
 tooth shape according ISO 606
 temperature range –40°C until 120°C
 screw DIN 933 ISO 4017 steel 8.8 galvanised
 hex-nut DIN 439 B ISO 4035 steel 8.8 galvanised
 components are loosely packed

SCHWINGELEMEN OSCILLATING UNITS

OM/DH/GSM

CH/CH PL/CH HL

CS

CE

DB-C/DB-F/DB-FM

TB-C/TB-F/TB-FM

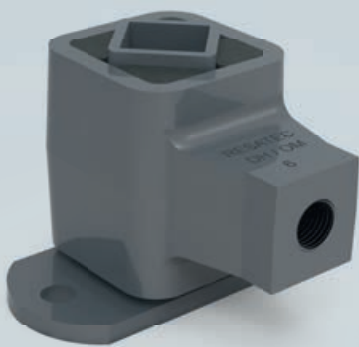

OM



CH



CS



CE

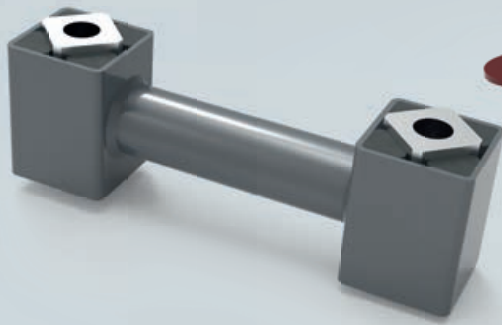

DB-C

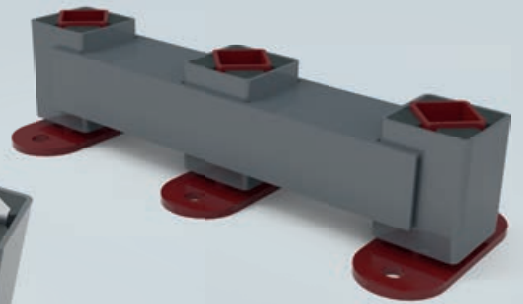

TB-F

SCHWINGELEMENT TYP OM

OSCILLATING MOUNT TYPE OM



RESATEC SCHWINGELEMENT TYP OM:

Die RESATEC Schwingelemente Typ OM sind die Kopfstücke eines Lenkerarms und für den Einsatz in einem Einmassen-Schwingsystem bis zur Schwingmaschinenkennzahl 1,6 oder im Resonanzbetrieb bis 2,2 geeignet. Die Flansche werden direkt an der Rinne und an der Maschinenstruktur angeschraubt. In die Gewinde lassen sich beliebig lange Verbindungsstangen (kundenseitig hergestellt) einbringen. Durch die Verwendung der Schwingelemente OM, einseitig mit Rechts- und gegenüberseitig mit Linksgewinde, kann der Achsabstand stufenlos nivelliert werden.

RESATEC OSCILLATING MOUNT TYPE OM:

The RESATEC oscillating mount type OM are the head pieces of a rocker arm and are suitable for use in a single-mass crank shaft driven conveyor system up to oscillating machine index 1.6 or in resonance mode up to 2.2. The flanges are bolted directly to the trough and to the machine structure. Connecting rods of any length (made by customer) can be inserted into the threads. By using the swinging elements OM, one side with right-hand thread and the other side with left-hand thread, the center distance can be continuously leveled.

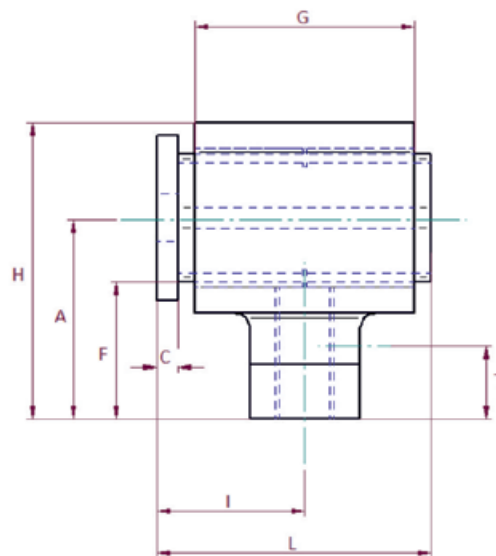
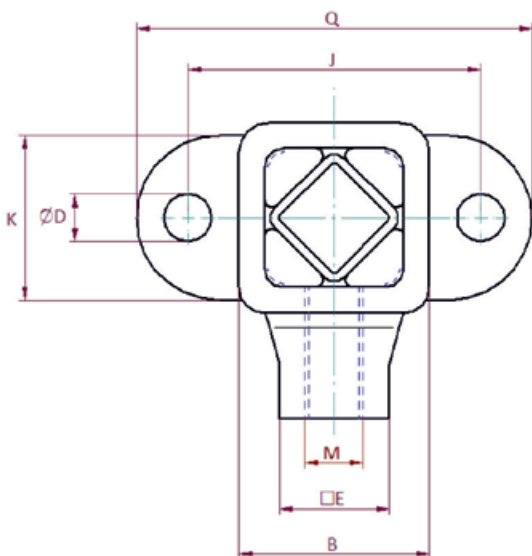

Typ type	Art. Nr. art. no.	max. Kraft max. force	Modul [Nm/°] @ +/- 5° +300 - 600	max. nerr															Gewicht weight	Material		
					A	B	C	øD	□E	F	G	H	I	J	K	L	M	Q		T	Gehäuse housing	Innenteil core
		N	min ⁻¹	min ⁻¹															kg			
OM 4 – 50R	570 040 50	200	1.31	30	40	36	5	9	24	25	50	58	33	60	30	61	M12R	82	16	0.27	EN AC-AL	Stahl/steel 5235JR SN EN ISO 13920 AE
OM 4 – 50L	570 140 50	200	1.31	50	40	36	5	9	24	25	50	58	33	60	30	61	M12L	82	16	0.27		
OM 5 – 60R	570 050 60	400	3.00	80	55	52	7	11	30	35	60	81	41	80	45	75	M16R	109	24	0.65		
OM 5 – 60L	570 150 60	400	3.00	40	55	52	7	11	30	35	60	81	41	80	45	75	M16L	109	24	0.65		
OM 6 – 80R	570 060 80	800	7.6	60	80	72	8	14	40	52	80	115	53	100	60	97	M20R	130	30	1.5		
OM 6 – 80L	570 160 80	800	7.6	100	80	72	8	14	40	52	80	115	53	100	60	97	M20L	130	30	1.5		
OM 6 – 80R 30 °R	570 060 82	800	7.6	60	80	72	8	14	40	52	80	115	53	100	60	97	M20R	130	30	1.5		
OM 6 – 80R 30 °L	570 060 83	800	7.6	80	80	72	8	14	40	52	80	115	53	100	60	97	M20R	130	30	1.5		
OM 7 – 100R	570 071 00	1600	12.4	120	90	90	9	17	50	55	100	135	63	130	70	118	M24R	170	36	2.6		
OM 7 – 100L	570 171 00	1600	12.4	80	90	90	9	17	50	55	100	135	63	130	70	118	M24L	170	36	2.6		
OM 8 – 120R	570 081 20	2600	26.9	100	100	92	10	17	60	65	120	148	75	140	80	140	M36R	180	55	6.1	EN GJS-400 ISO8062-3- DCTG11	
OM 8 – 120L	570 181 20	2600	26.9	150	100	92	10	17	60	65	120	148	75	140	80	140	M36L	180	55	6.1		

SCHUBSTANGENKOPF TYP DH/GSM

DRIVE HEAD TYPE DH/GSM



DH



GSM

RESATEC SCHUBSTANGENKOPF TYP DH:

Der RESATEC Schubstangenkopf Typ DH ist das elastische Kopfstück der Schubkurbelstange. Am Exzenter kann wegen der vollen Rotation am Exzenterlager ein Kugel- oder Rollenlager verwendet werden. An der Rinne wird mit dem Schubstangenkopf trotz der Bewegung im reduzierten Winkelbereich eine wartungsfreie Übertragung der Antriebskräfte erreicht. Mit dem elastischen Schubstangen-Kopf werden die hohen Kraftspitzen, welche bei einer steifen Komponente zu erhöhtem Verschleiss führen reduziert und gleichermassen werden die Antriebskomponenten wie auch die Rinnenstruktur geschont.

RESATEC DRIVE HEAD TYPE DH:

The RESATEC drive head type DH is the elastic head piece of the push crank rod. A ball or roller bearing can be used on the eccentric drive side. At the trough, the drive head achieves maintenance-free transmission of the drive forces. The elastic drive head reduces the high force peaks that lead to increased wear in a stiff component and at the same time protects the drive components and the trough structure.

RESATEC SCHWINGELEMENT TYP GSM:

GSM ist funktionell ein DH mit grösserem Gummivolumen. Es wird ein grösserer Kopf verwendet und mit grösserem Gummiuerschnitt kompensiert. GSM kommen vorwiegend zur Aufhängung von Plansichtern in Einsatz.

RESATEC OSCILLATING MOUNT TYPE GSM:

GSM is functionally a DH with larger rubber volume. A larger head is used and compensated with larger rubber cross section. GSM are mainly used for the suspension of plansifters.

$$F = m \times R \times 0.001 \times (2\pi \times n_{\text{neer}})^2$$

F [N] Beschleunigungskraft
Acceleration force

m [kg] Schwingende Masse
Oscillating mass

R [mm] Exzenteradius
Eccentric radius

n_{neer} [min⁻¹] Erreger-Drehzahl
Excitation rpm

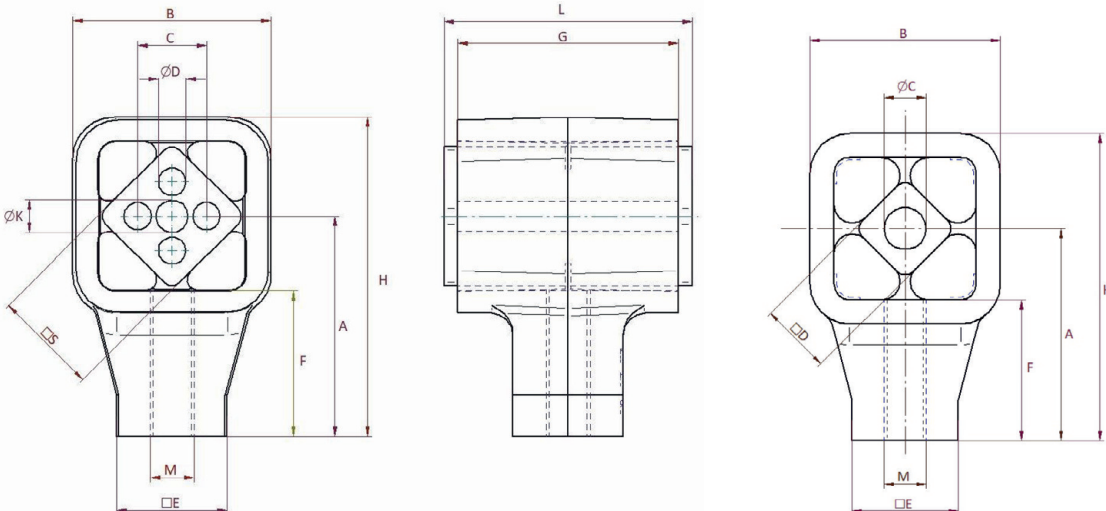

Abmasse/Material/
dimensions/material

Leistungsdaten/performance

Typ type	Art. Nr. art. no.	max. Kraft max. force	Winkel angle	max. nerr		A	B	C	øD	øK	□E	F	G	H	L+0/-0.3	M	T	□S	Gewicht weight	Material	Gehäuse housing	Innenteil core
				max.	min ⁻¹																	
DH 4 – 50R	571 040 50	400	10°	720	40	36	12	6	–	24	25	50	58	55	M12R	16	18	0.15	EN ACAL	Aluminium-Knetlegierung T6/Aluminium-wrought alloys T6		
DH 4 – 50L	571 140 50	400	10°	720	40	36	12	6	–	24	25	50	58	55	M12L	16	18	0.15				
DH 5 – 60R	571 050 60	1 000	10°	680	55	52	20	8	–	30	35	60	81	65	M16R	24	27	0.35				
DH 5 – 60L	571 150 60	1 000	10°	680	55	52	20	8	–	30	35	60	81	65	M16L	24	27	0.35				
DH 6 – 80R	571 060 80	2 000	10°	620	80	72	25	10	–	40	52	80	115	90	M20R	30	38	1				
DH 6 – 80L	571 160 80	2 000	10°	620	80	72	25	10	–	40	52	80	115	90	M20L	30	38	1				
DH 7 – 100R	571 071 00	3 500	10°	580	90	90	35	12	17	50	55	100	135	110	M24R	36	45	1.7				
DH 7 – 100L	571 171 00	3 500	10°	580	90	90	35	12	16.5	50	55	100	135	110	M24L	36	45	1.7				
DH 8 – 120R	571 081 20	6 000	10°	560	100	100	40	M12×40	20.5	60	65	120	148	130	M36R	55	50	4.9				
DH 8 – 120L	571 181 20	6 000	10°	560	100	100	40	M12×40	20.5	60	65	120	148	130	M36L	55	50	4.9				
DH 9 – 200R	571 092 00	11 500	10°	540	120	120	45	M16×25	–	80	75	200	183	210	M42R	63	60	17.9	EN GJS-400 ISO 8062-3-DC1G11	Aluminium-Knetlegierung T6/Aluminium-wrought alloys T6		
DH 9 – 200L	571 192 00	11 500	10°	540	120	120	45	M16×25	–	80	75	200	183	210	M42L	63	60	17.9				
DH 9 – 300R	571 093 00	17 500	10°	540	120	120	45	M16×25	–	80	75	300	183	310	M42R	63	60	25.5				
DH 9 – 300L	571 193 00	17 500	10°	540	120	120	45	M16×25	–	80	75	300	183	310	M42L	63	60	25.5				
DH 11 – 300R	571 113 00	25 000	10°	440	168	152	60	M20×30	–	100	100	300	236	310	M52R	78	80	41.5	SN EN ISO 3920 AE	Stahl/steel S235JR ISO 2768mK		
DH 11 – 300L	571 213 00	25 000	10°	440	168	152	60	M20×30	–	100/136	100	300	236	310	M52L	78	80	41.5				

Abmasse/Material/dimensions/material

Typ type	Art. Nr. art. no.	max. Belastung pro Einheit max. load/unit	G	L	F	E	A	C	B	D	H	M	Gummi ø/ rubber ø	Gewicht weight
GSM 4 R	571 300 40	700 – 1 700	60	65	35	30	55	13	52	18	81	M16R	20	0.35
GSM 4 L	571 400 40	700 – 1 700	60	65	35	30	55	13	52	18	81	M16L	20	0.35
GSM 5 R	571 300 50	1 400 – 3 200	80	90	52	40	80	16.5	72	27	115	M20R	25	1
GSM 5 L	571 400 50	1 400 – 3 200	80	90	52	40	80	16.5	72	27	115	M20L	25	1
GSM 6 R	571 300 60	2 800 – 5 200	100	110	55	50	90	21	90	38	135	M24R	27	1.7
GSM 6 L	571 400 60	2 800 – 5 200	100	110	55	50	90	21	90	38	135	M24L	27	1.7
GSM 7 R	571 300 70	4 800 – 7 900	120	130	65	60	100	21	94	40	148	M36R	35	4.9
GSM 7 L	571 400 70	4 800 – 7 900	120	130	65	60	100	21	94	40	148	M36L	35	4.9
GSM 8 R	571 300 80	6 500 – 17 000	200	210	75	80	120	4×M12×40	120	50	183	M42R	40	17.9

Belastung [N] :

$$\frac{m \times g}{z}$$

Total schwingende Masse

m [kg]

Anzahl Aufhängungen

z [Stück]

Beschleunigung

g [9,81m/s²]

SIEBLAGERUNG TYP CH

SCREEN MOUNT TYPE CH



CH



CH-I

RESATEC SIEBLAGERUNG TYP CH: (CH-I = INOX-AUSFÜHRUNG)

Die RESATEC Sieblagerung Typ CH ist die universale Abstützung in unserem Sortiment. Alle Vorteile, wie grosse Schwingweiten, hohe Isolierwirkung, hohe Leistungsdichte, geringe Restkraftübertragung und hohe Resistenz bezüglich Spontanbeschickung sind vereint. Ebenso ist die Lagerung geneigter Siebe möglich. Quer wirkende Zugkräfte durch Riementreibe werden gut absorbiert und verhindern eine negative, einseitige Förderung.

RESATEC SCREEN MOUNT TYPE CH: (CH-I = INOX/STAINLESS STEEL)

The RESATEC screen mount type CH is the universal mounting in our product range. All advantages, such as large oscillation amplitudes, high insulating effect, high power density, low residual force transmission and high resistance with regard to spontaneous loading are combined. The support of inclined screens is also possible. Transversely acting tensile forces due to belt drives are well absorbed and prevent negative, one-sided conveying.

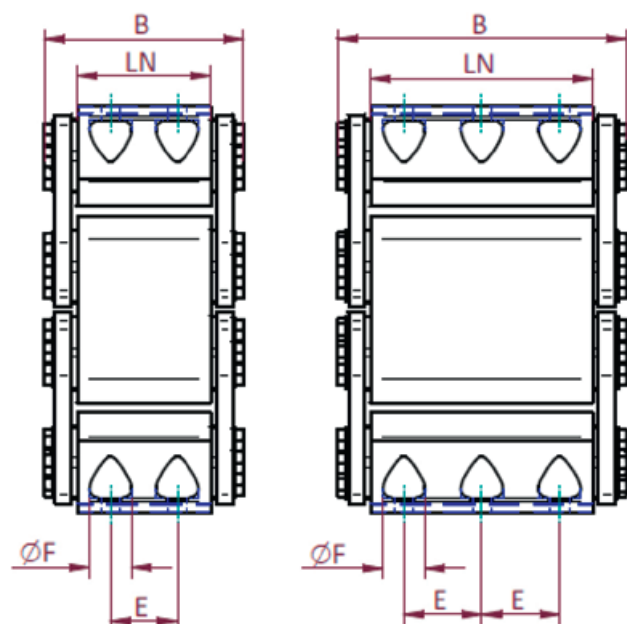
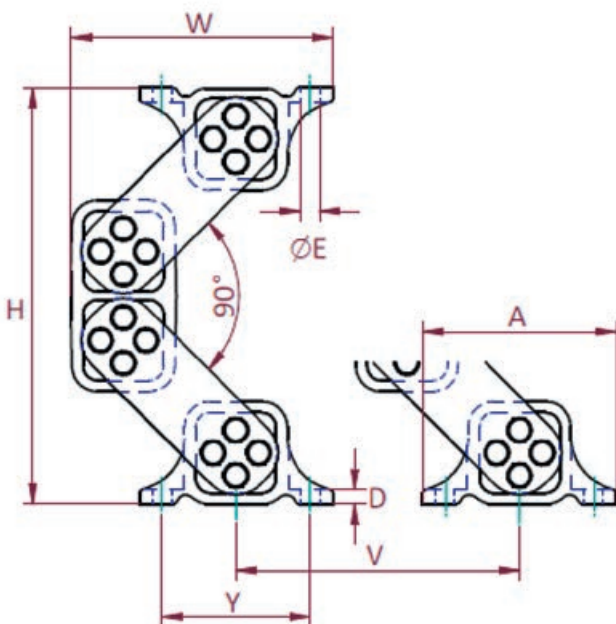

Typ type	Art. Nr. art. no.	H		W		A	B	LN	D	E	øE	Schrauben SCREWS	øF +/- 0.2	Y	V	Gewicht weight	Material			
		unbelastet unloaded	max. Last max. load	unbelastet unloaded	max. Last max. load											min.	kg	Gehäuse housing	Innenteil core	Hebel lever
CH-I 3-40	556 403 02	163	123-118	102	116-117	65	52	40	4	-	7	4	-	50	120	0.9	SINT-C 40		1.4301	
CH-I 4-50	556 404 02	210	150-143	130	137-130	85	61	50	4.5	-	9	4	-	65	150	1.6	SINT-C 41		1.4301	
CH 5-60	556 105 02	236	180-173	148	167-169	105	80	60	5	-	11	4	-	80	170	2.2	Aluminium	Aluminium	Stahl Pulverlackierung steel powder coating	
CH 6-80	556 106 02	305	234-224	184	209-211	125	106	80	6	40	13	8	-	100	210	5			Stahl mit Pulverlackierung steel with powder coating	
CH 7-110	556 107 02	333	256-245	206	233-235	145	155	110	8	65	13	8	-	115	240	8				
CH 8-120	556 108 01	366	277-264	230	260-263	170	172	120	13	60	17	8	38	130	270	16				
CH 8-160	556 108 02		277-264		260-263		212	160		2x60		12				18.4				
CH 8-200	556 108 03		277-264		260-263		252	200		2x70		12				21.3				
CH 8-240	556 108 04		277-264		260-263		300	240		3x60		16				24				
CH 8-320	556 108 05		277-264		260-263		380	320		4x60		20				29.3				
CH 8-400	556 108 06	277-264	260-263	460	400	4x70	20	34.7												

Belastungswerte/load values, max. Einsatzparameter/capacity limits

Typ type	Art. Nr. art. no.	Belastung load		Eigen- frequenz fe natural frequency fe		Dynam. Federrate cd dynam. spring ratio cd 960 min ⁻¹			max. Einsatzparameter/capacity limits*											
		min. N	max. N	min. Hz	max. Hz	verti. N/mm	sw amplitude		720 min ⁻¹ (12 Hz)				960 min ⁻¹ (16 Hz)				1440 min ⁻¹ (24 Hz)			
							peak to peak mm	hori. N/mm	sw mm	K -	W %	Vm m/min.	sw mm	K -	W %	Vm m/min.	sw mm	K -	W %	Vm m/min.
CH-I 3-40	556 403 02	50	160	4.5	2.4	10	11	13	13.5	3.9	95.4	16	11	5.7	97.4	17	8	9.3	99	18
CH-I 4-50	556 404 02	120	350	4	2.3	19	12	15	16	4.9	96.8	18	14	7.7	98.3	19	8	9.3	99	18
CH 5-60	556 105 02	240	800	3.8	2.2	35	14	18	17	4.9	96.6	20	14	8.8	98.1	24	8	9.3	99	18
CH 6-80	556 106 02	600	1600	3.0	1.9	56	17	26	20	5.8	97.3	24	17	8.8	98.5	27	8	9.3	99	18
CH 7-110	556 107 02	1300	3300	2.8	1.9	107	17	38	20	5.8	97.5	24	17	9.3	98.5	27	8	9.3	99	18
CH 8-120	556 108 01	2400	5800	2.4	1.9	194	18	84	22	6.4	97.5	26	18	9.3	98.5	28	8	9.3	99	18
CH 8-160	556 108 02	3200	8000	2.4		266		138			97.5									
CH 8-200	556 108 03	4000	9800	2.4		327		149			97.5									
CH 8-240	556 108 04	5000	12000	2.3		399		209			97.5									
CH 8-320	556 108 05	7000	16000	2.2		533		277			97.5									
CH 8-400	556 108 06	8500	20000	2.3	666	344	97.8													

*sw = Schwingweite/amplitude (peak to peak)
 K = Schwingmaschinenkennzahl/oscillating machine factor
 W = Schwingisolation/isolation efficiency
 Vm = theo. Material-Fördergeschwindigkeit/theo. conveying speed
 (Winkel/angle 45°)



SIEBLAGERUNG TYP CH-PL

SCREEN MOUNT TYPE CH-PL



RESATEC SIEBLAGERUNG TYP CH-PL:

Die RESATEC Sieblagerung Typ CH-PL ist die Optimierung bezüglich der Leistungsdichte. Ausreichende Schwingweiten, gute Isolierwirkung und gute Resistenz bezüglich Spontanbeschickung bleiben erhalten. Auch die Lagerung geneigter Siebe ist möglich. Ist als Antrieb der Unwucht-Wellen ein Riementrieb vorgesehen, empfehlen wir den Einsatz einer elastischen Motorenlagerung (z. Bsp. RESATEC Motorwippe MW-8).

RESATEC SCREEN MOUNT TYPE CH-PL:

The RESATEC screen mount type CH-PL is the optimization in terms of power density. Sufficient oscillation amplitudes, good insulating effect and good resistance with regard to spontaneous loading are retained. The support of inclined screens is also possible. If a belt drive is intended to drive the unbalance shafts, we recommend the use of a motor base (e.g. RESATEC motor base MW-8).

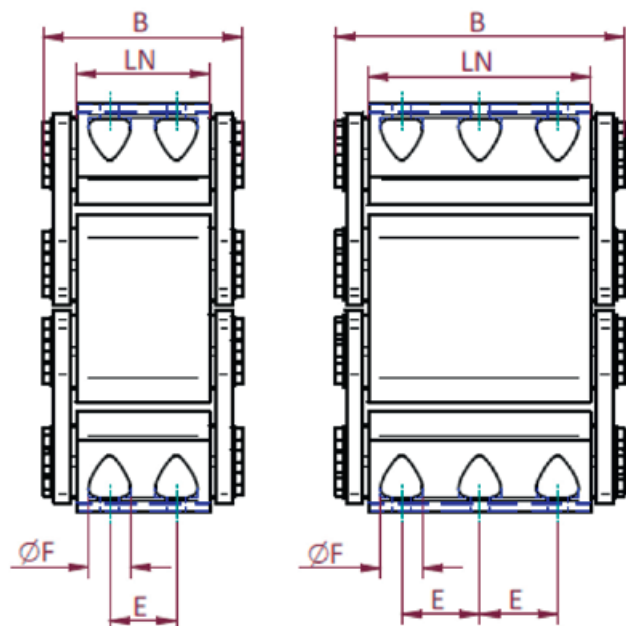
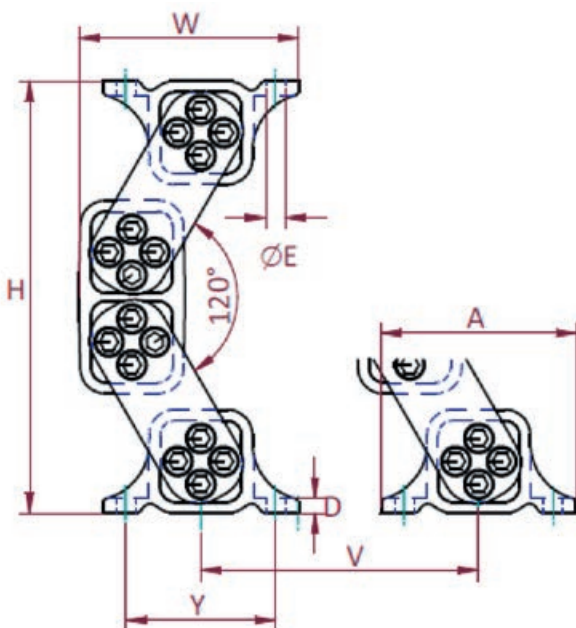

Typ type	Art. Nr. art. no.	H		W		A	B	LN	D	E	øE	Schrauben SCREWS	øF +/- 0.2	Y	V	Gewicht weight	Material			
		unbelastet unloaded	max. Last max. load	unbelastet unloaded	max. Last max. load											min.	kg	Gehäuse housing	Innenteil core	Hebel lever
CH-I PL 3 – 40	556 430 01	135	118 – 115	70	80 – 82	65	52	40	4	–	7	4	–	50	80	1	SINT-C 40		1.4571	
CH-I PL 4 – 50	556 440 01	242	175 – 163	110	159 – 165	85	61	50	4.5	–	9	4	–	65	200	1.6	SINT-C 41		1.4571	
CH-PL 7 – 110	556 207 02	340	290 – 283	170	199 – 202	145	145	110	8	65	13	8	–	115	220	7.9	Aluminium	Stahl Pulverlackierung steel powder coating		
CH-PL 8 – 120	556 208 01		315 – 307		226 – 229		180	120		60		8				15.8				
CH-PL 8 – 160	556 208 02		315 – 305		226 – 230		220	160		2x60		12				18.3		Aluminium	Stahl mit Pulverlackierung steel with powder coating	
CH-PL 8 – 200	556 208 03	376	315 – 307	191	226 – 229	170	260	200	13	2x70	17	12	38	130	240	21.2				
CH-PL 8 – 240	556 208 04		314 – 306		226 – 229		300	240		3x60		16				23.9				
CH-PL 8 – 320	556 208 05		315 – 305		226 – 230		380	320		4x60		20				29.3				
CH-PL 8 – 400	556 208 06		315 – 307		226 – 229		460	400		4x70		20				34.6				

Belastungswerte/load values, max. Einsatzparameter/capacity limits

Typ type	Art. Nr. art. no.	Belastung load		Eigen- frequenz fe natural frequency fe		Dynam. Federrate cd dynam. spring ratio cd 960 min ⁻¹			max. Einsatzparameter/capacity limits*												
		min. N	max. N	min. Hz	max. Hz	verti. N/mm	sw amplitude		hori. N/mm	720 min ⁻¹ (12 Hz)				960 min ⁻¹ (16 Hz)				1440 min ⁻¹ (24 Hz)			
							peak to peak mm			sw mm	K –	W %	Vm m/min.	sw mm	K –	W %	Vm m/min.	sw mm	K –	W %	Vm m/min.
CH-I PL 3 – 40	556 430 01	120	300	6.2	3.5	27	7	18	8	2.3	90.5	9.5	7	3.6	95	10.8	5	5.8	97.8	11.7	
CH-I PL 4 – 50	556 440 01	250	800	5.1	3.2	38	9	25	10	2.8	92.5	12.2	9	4.5	94	13.2	7	8	97.1	13.5	
CH-PL 7 – 110	556 207 01	2 000	4 500	3.4	2.1	170	14	86	17	4.9	97	20.5	14	7.1	98	22.5	8	9.3	98.5	18	
CH-PL 8 – 120	556 208 01	3 500	8 100	2.6	2.1	281		128			97				98						
CH-PL 8 – 160	556 208 02	4 700	11 300	2.9	2.1	388		171			97				98						
CH-PL 8 – 200	556 208 03	6 000	13 600	2.6	1.9	471	15	215	18	5.2	97	21	15	7.7	98	24	8	9.3	98.5	18	
CH-PL 8 – 240	556 208 04	8 000	16 000	2.5	1.9	506		259													90.5
CH-PL 8 – 320	556 208 05	11 000	22 000	2.5	1.9	760		344													97
CH-PL 8 – 400	556 208 06	13 500	27 000	2.5	2	939		432													97

*sw = Schwingweite/amplitude (peak to peak)
 K = Schwingmaschinenkennzahl/oscillating machine factor
 W = Schwingisolation/isolation efficiency
 Vm = theo. Material-Fördergeschwindigkeit/theo. conveying speed
 (Winkel/angle 45°)



SIEBLAGERUNG TYP CH-HL

SCREEN MOUNT TYPE CH-HL

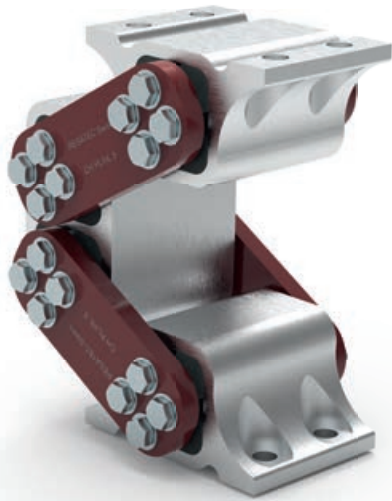

RESATEC SIEBLAGERUNG TYP CH-HL:

Die RESATEC Sieblagerung Typ CH-HL ermöglicht die Lagerung hängender Siebe. Alle Vorteile, wie grosse Schwingweiten, hohe Isolierwirkung, hohe Leistungsdichte, geringe Restkraftübertragung, hohe Resistenz bezüglich Spontanbeschickung sind vereint. Ebenso ist die Lagerung geneigter Siebe möglich. Quer wirkende Zugkräfte durch Riementreibe werden gut absorbiert und verhindern eine negative einseitige Förderung. Obwohl die RESATEC-Sieblagerung Typ CH-HL abreiss- und bruchsicher ist, sind für hängende Anlagen die CE-Richtlinien zu berücksichtigen.

RESATEC SCREEN MOUNT TYPE CH-HL:

The RESATEC screen mount type CH-HL enables the mounting of hanging screens. All advantages, such as large oscillation amplitudes, high insulating effect, high power density, low residual force transmission, high resistance with regard to spontaneous feeding are combined. Also inclined screens are also possible. Transversely acting tensile forces due to belt drives are well absorbed and prevent negative one-sided conveying. Although the RESATEC screen mounting type CH-HL is tear- and break-proof, the CE guidelines must be taken into account for hanging installations.

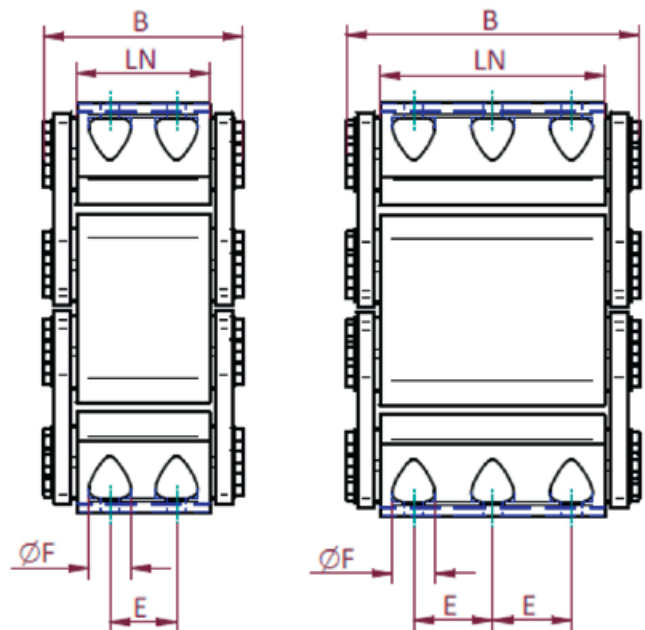
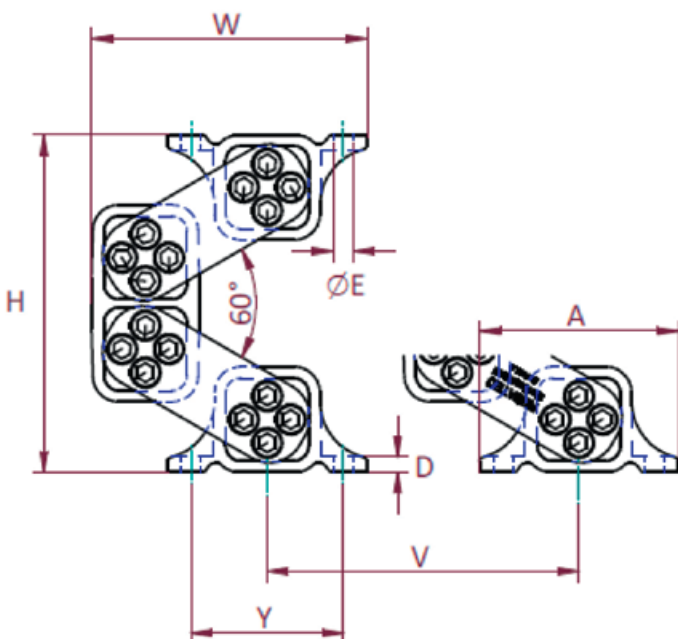

Typ type	Art. Nr. art. no.	H		W		A	B	LN	D	E	øE	Schrauben SCREWS	øF +/- 0.2	Y	V	Gewicht weight	Material			
		unbelastet unloaded	max. Last max. load	unbelastet unloaded	max. Last max. load											min.	kg	Gehäuse housing	Innenteil core	Hebel lever
CH-HL 3 – 40	556 303 02	102	123 – 126	86	79 – 76	65	52	40	4	–	7	4	–	50	80	1.0	SINT-C 40		1.4571	
CH-HL 4 – 50	556 304 02	169	204 – 207	147	132 – 129	85	61	50	4.5	–	9	4	–	65	200	1.6	SINT-C 41		2.4571	
CH-HL 7 – 110	556 307 02	259	314 – 321	210	187 – 183	145	145	110	8	65	13	8	–	115	220	7.9	Aluminium	Stahl Pulverlackierung steel powder coating		
CH-HL 8 – 120	556 308 01	288	354 – 361	235	207 – 203	170	180	120	13	60	17	8	38	130	240	15.8				Aluminium
CH-HL 8 – 160	556 308 02		354 – 361		207 – 203		220	160		2x60		12				18.3				
CH-HL 8 – 200	556 308 03		356 – 361		207 – 203		260	200		2x70		12				21.2				
CH-HL 8 – 240	556 308 04		353 – 360		208 – 203		300	240		3x60		16				23.9				
CH-HL 8 – 320	556 308 05		354 – 360		207 – 203		380	320		4x60		20				29.3				
CH-HL 8 – 400	556 308 06		353 – 360		208 – 204		460	400		4x70		20				34.6				

Belastungswerte/load values, max. Einsatzparameter/capacity limits

Typ type	Art. Nr. art. no.	Belastung load		Eigen- frequenz fe natural frequency fe		Dynam. Federrate cd dynam. spring ratio cd 960 min ⁻¹			max. Einsatzparameter/capacity limits*											
		min. N	max. N	min. Hz	max. Hz	verti. N/mm	sw amplitude		720 min ⁻¹ (12 Hz)				960 min ⁻¹ (16 Hz)				1440 min ⁻¹ (24 Hz)			
							hori. N/mm	peak to peak mm	sw mm	K –	W %	Vm m/min.	sw mm	K –	W %	Vm m/min.	sw mm	K –	W %	Vm m/min.
CH-HL 3 – 40	556 303 02	120	300	5.7	4.6	26	7	15	8	2.3	84	9.5	7	3.5	91.1	10.8	5	5.8	96.2	11.7
CH-HL 4 – 50	556 403 02	270	800	5.2	4.2	37		24												
CH-HL 7 – 110	556 307 02	2000	4500	3.2	2.8	161	14	86	17	4.9	93.7	20.5	14	7.1	96.8	22.5	8	9.3	98.6	18
CH-HL 8 – 120	556 308 01	3500	8400	2.6	2.8	281	15	117	18	5.3	94.2	21	15	7.7	96.8	24	8	9.3	98.6	18
CH-HL 8 – 160	556 308 02	4700	11300			378		157												
CH-HL 8 – 200	556 308 03	6000	14000			467		196												
CH-HL 8 – 240	556 308 04	7200	16000			528		230												
CH-HL 8 – 320	556 308 05	9000	22000			731		311												
CH-HL 8 – 400	556 308 06	12000	27000			895		386												

*sw = Schwingweite/amplitude (peak to peak)
 K = Schwingmaschinenkennzahl/oscillating machine factor
 W = Schwingisolation/isolation efficiency
 Vm = theo. Material-Fördergeschwindigkeit/theo. conveying speed
 (Winkel/angle 45°)

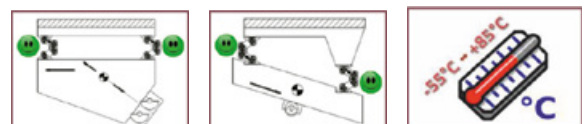

SIEBLAGERUNG TYP CS SCREEN MOUNT TYPE CS



RESATEC SIEBLAGERUNG TYP CS:

Die RESATEC Sieblagerung Typ CS ist die Optimierung bezüglich der Bauhöhe. Reduzierte Schwingweiten und gute Isolierwirkung bleiben erhalten. Spezifisch für die Lagerung von horizontal stehenden Förderanlagen (Linearförderer) mit meist kleineren Schwingweiten. Die zur Reihe CH veränderte Bauart ergibt eine Verstimmung in der Eigenfrequenz der Lagerungen. Somit kann die RESATEC-Sieblagerung Typ CS auch als Lagerung zwischen dem Fundament und einem Gegenschwingrahmen, in Kombination mit unseren Abstützungen Typ CH und CH-PL zwischen dem Gegenschwingrahmen und dem schwingenden Sieb, eingesetzt werden.

RESATEC SCREEN MOUNT TYPE CS:

The RESATEC screen mount type CS is the optimization with regard to the overall height. Reduced vibration amplitudes and good insulating effect are maintained. Specific for the mounting of horizontally standing conveyors (linear conveyors) with mostly smaller oscillation amplitudes. The design, which is different from the CH series, results in a detuning in the natural frequency of the mounts. Thus, the RESATEC screen mount type CS can also be used as a support between the foundation and a counter-swinging frame in combination with our mountings type CH and CH-PL between the counter-swinging frame and the swinging screen.

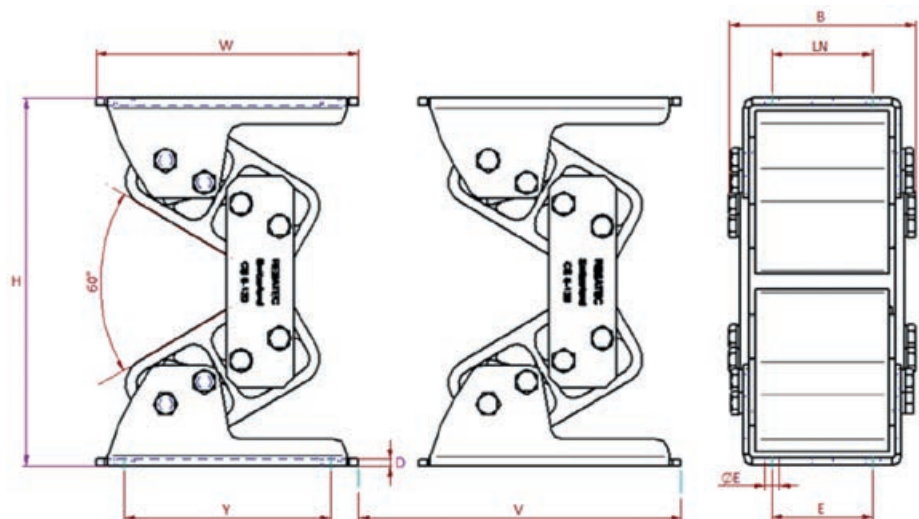
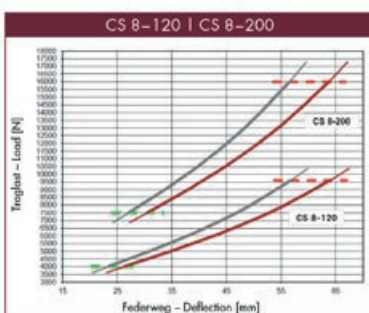
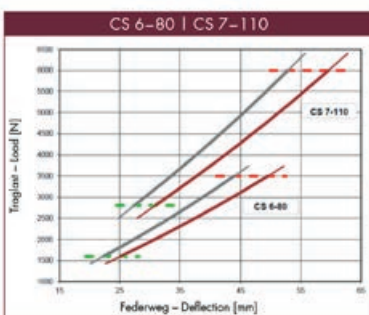
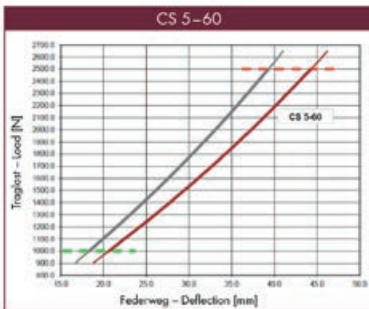

— max. Belastung – max. Load — min. Belastung – min. Load — Einfeldung bis 1 Tag – Deflection while 1 Day — Einfeldung bis 1 Jahr – Deflection while 1 Year

Abmasse/Material/dimensions/material

Typ type	Art. Nr. art. no.	unbelastet unloaded	H max. Last max. load	W	B	LN	D	E	øE +/- 0.2	Y	V	Gewicht weight	Material		
													Gehäuse housing	Innenteil core	Hebel lever support
CS 5 – 60	556 005 02	184	145 – 139	150	94	60	4	40	9	120	165	3.2	Aluminium	Aluminium	Stahl mit Pulverlackierung steel with powder coating
CS 6 – 80	556 006 02	244	200 – 193	176	126	80	5	50	11	150	185	5.9			
CS 7 – 110	556 007 02	298	245 – 237	220	159	110	6	80	13.5	170	230	10.5			
CS 8 – 120	556 008 01	329	272 – 266	235	164	120	6	90	13.5	185	245	13.6			
CS 8 – 200	556 008 03			235	249	200	7.5	90				24.6			

Belastungswerte/load values, max. Einsatzparameter/capacity limits

Typ type	Art. Nr. art. no.	Belastung load		Eigen- frequenz fe natural frequency fe		Dynam. Federrate cd dynam. spring ratio cd 960 min ⁻¹			max. Einsatzparameter/capacity limits*											
				Belastung load		sw amplitude			720 min ⁻¹ (12 Hz)				960 min ⁻¹ (16 Hz)				1440 min ⁻¹ (24 Hz)			
				min. N	max. N	min. Hz	max. Hz	verti. N/mm	peak to peak mm	hori. N/mm	sw mm	K -	W %	Vm m/min.	sw mm	K -	W %	Vm m/min.	sw mm	K -
CS 5 – 60	556 005 02	1 000	2 500	3.9	2.9	124	5.5	58	6.5	1.9	93.7	7	5.5	2.8	96.6	9	4.3	5	98.5	7
CS 6 – 80	556 006 02	1 600	3 500	3.5	2.5	127	8	68	10	2.8	94.8	12	8	4.2	97.2	13	6	7.4	98.8	14
CS 7 – 110	556 007 02	2 800	6 000	3.2	2.3	195	9	100	11	3.2	95.7	13	9	4.8	97.6	15	7	8.5	99	17
CS 8 – 120	556 008 01	4 000	9 600	2.6	2.4	328	10	129	12	3.5	95.5	14	10	5.1	97.5	16	8	9.3	99	18
CS 8 – 200	556 008 03	7 500	16 000	2.6	2.4	551	10	211												

*sw = Schwingweite/amplitude (peak to peak)
 K = Schwingmaschinenkennzahl/oscillating machine factor
 W = Schwingisolation/isolation efficiency
 Vm = theo. Material-Fördergeschwindigkeit/theo. conveying speed
 (Winkel/angle 45°)



PLANSICHTERLAGERUNG TYP CE

GYRATORY SIFTER MOUNT TYPE CE



RESATEC PLANSICHTERLAGERUNG TYP CE:

Das RESATEC Plansichterlager Typ CE ermöglicht die Lagerung von hängenden und stehenden Freischwinger, wie auch stehende Plansichter mit Exzenter-Zwangs-führung. Die Paarung zweier Elemente in einer Stütze ermöglicht eine kreisrunde und ebene Schwingbewegung. Obwohl RESATEC-Plansichterlagerungen Typ CE abreiss- und bruchsicher sind, sind für hängende Anlagen die CE-Richtlinien zu berücksichtigen.

RESATEC GYRATORY SIFTER MOUNT TYPE CE:

The RESATEC gyratory sifter mount type CE enables the mounting of hanging and standing gyratory sifters, as well as standing gyratory sifters with eccentric forced guidance. The pairing of two elements in one support enables a circular and plane oscillating movement. Although RESATEC type CE gyratory sifters are tear and break resistant, CE safety guidelines must be taken into account for hanging installations.

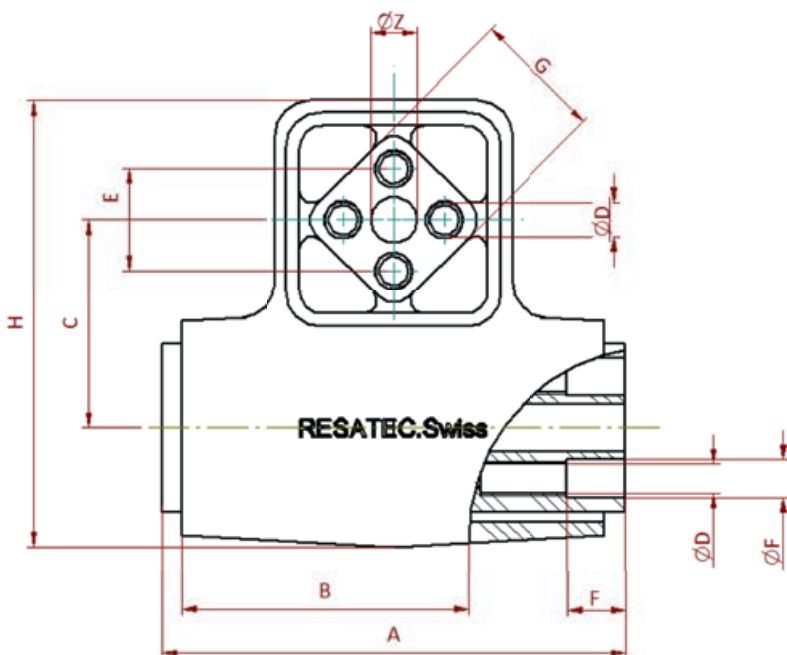

Abmasse/Material/dimensions/material

Typ type	Art. Nr. art. no.	H	A +0/-0.3	B	C	øD	F	G	øF	E	øZ	Gewicht weight	Material		
						+0,5 0						kg	Gehäuse housing	Innenteil core	
CE 4 – 80	572 040 80	64	85	80	32	6	–	18	–	12	–	0.6	EN GIS 400 ISO 8062-3-DCTG11	Strahl mit Pulverlackierung steel with powder coating	Aluminium
CE 5 – 100	572 051 00	97	105	100	45	8	–	27	–	20	–	1.7			
CE 6 – 120	572 061 20	130	130	120	60	10	–	38	–	25	–	3.6			
CE 7 – 150	572 071 50	154	160	150	72	12	–	45	–	35	16	6.6			
CE 8 – 200	572 082 00	172	210	200	78	M12×30	25	50	12.5	40	20	10.8			
CE 9 – 300	572 093 00	218	310	292	100	M16×40	70	60	16.5	45	–	35.2			
CE 11 – 400	572 114 00	280	410	390	136	M20×40	70	80	20.5	60	–	72			
CE 12 – 400	572 124 00	340	410	390	170	M24×50	70	100	25	75	–	107	Stahl/steel SN EN ISO 13920 AE	Stahl steel	
CE 12 – 500	572 125 00		510	500		M24×50					30H7×30	135			

Belastungswerte/load values, max. Einsatzparameter/capacity limits

Typ type	Art. Nr. art. no.	Belastung stehende Ausführung mit Exenterantrieb load upright version crank shaft driven	Belastung stehende Ausführung mit Unwucht-Antrieb load upright version unbalanced shaft driven	Belastung hängende Ausführung load hanging version	max. Drehzahl max. excitation speed nerr @ max. Schwingwinkel oscillating angle +/- 5°	passende Montagewinkel suitable brackets	
		Typ type	N	N	min ⁻¹	Typ type	Art. Nr. art. no.
CE 4 – 80	572 040 80	300	190	375	800	MA 3 – 4	580 003 04
CE 5 – 100	572 051 00	750	470	900	780	MA 4 – 5	580 004 05
CE 6 – 120	572 061 20	1 500	940	1 875	780	MA 5 – 6	580 005 06
CE 7 – 150	572 071 50	2 800	1 750	3 500	580	MA 6 – 7	580 006 07
CE 8 – 200	572 082 00	5 500	3 400	6 800	400	MA 7 – 8	580 007 08
CE 9 – 300	572 093 00	9 500	5 900	11 800	300	–	–
CE 11 – 400	572 114 00	18 000	11 250	22 500	150	–	–
CE 12 – 400	572 124 00	32 000	20 000	40 000	100	–	–
CE 12 – 500	572 125 00	36 000	22 500	45 000		–	–

Wir empfehlen minimale Schrauben-Qualität 8,8.

Ab der Baugröße CE 8–200 die Verwendung von Schaftschrauben.
Gleiche Ausrichtung der Elemente an der Struktur und um 90° versetzt am Siebkasten.

Bei stehender Ausführung muss der Schwerpunkt unterhalb der Befestigungspunkte der Sieblagerung am Siebkasten liegen.

Der maximale Schwingwinkel ist +/- 5° sonst ist der Achsabstand bei der Stütze zu verlängern.

We recommend minimum screw quality 8.8.

From size CE 8–200 the use of shaft screws is recommended.

Same alignment of the elements on the structure and offset by 90° for the elements on the screen box.

In case of upright design, the centre of gravity must be below the connecting point of the mountings on the screen box.

The maximum angle of oscillation is +/- 5°, otherwise the center distance of the support must be extended

SCHWINGEN TYP DB-C/DB-F/DB-FM

ROCKER TYPE DB-C/DB-F/DB-FM

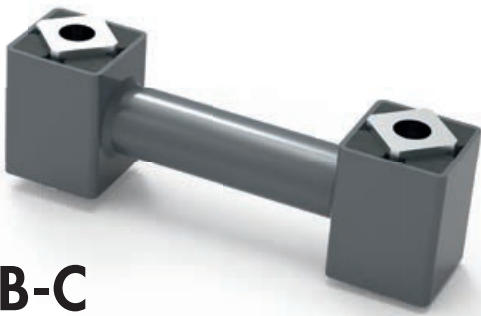

DB-C

RESATEC SCHWINGEN TYP DB-C/DB-F/DB-FM

Die RESATEC Schwinge Typ DB wird in kurbelwellengetriebenen Förder-, Sieb-, Sortieranlagen, etc. als geführtes Einmassensystem zur Rinnenabstützung eingesetzt. Die Schwingen haben normierte Achsabstände und sind für Schwingwinkel bis max. $\pm 6^\circ$ einsetzbar. Der Abstand zwischen den einzelnen Schwingen soll 1,5 m nicht überschreiten. Der Typ C ist für Zentralbefestigung und die Typen F und FM für Flanscbefestigung ausgelegt. Kunden-spezifische Ausführungen sind möglich.

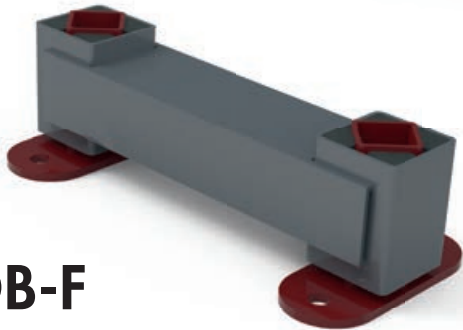

DB-F

RESATEC ROCKER TYPE DB-C/DB-F/DB-FM

The RESATEC single rocker type DB is used in crank shaft driven conveying, screening, sorting machines, etc. as a guided single mass system for trough support. The single rockers have standardized center distances and can be used for oscillation angles up to $\pm 6^\circ$. The distance between the individual rockers should not exceed 1.5 m. Type C is designed for central mounting and types F and FM for flange mounting. Customer-specific designs are possible.

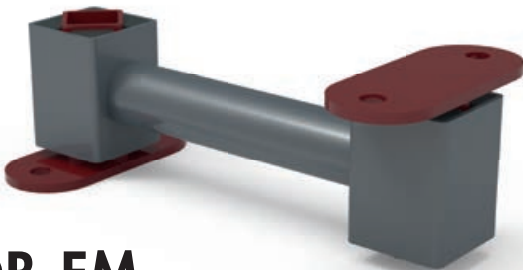

DB-FM

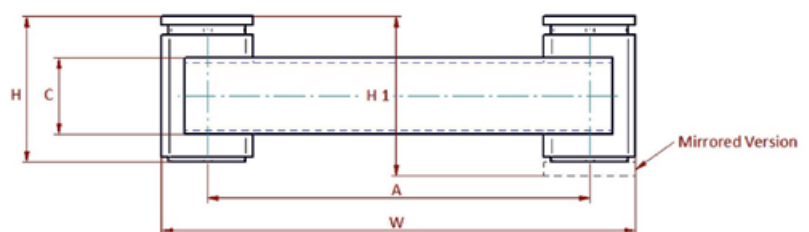
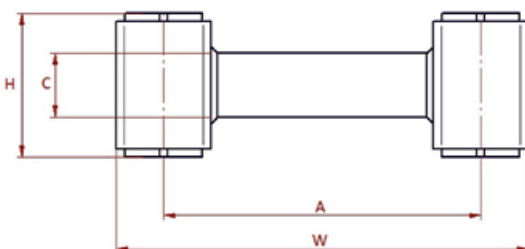
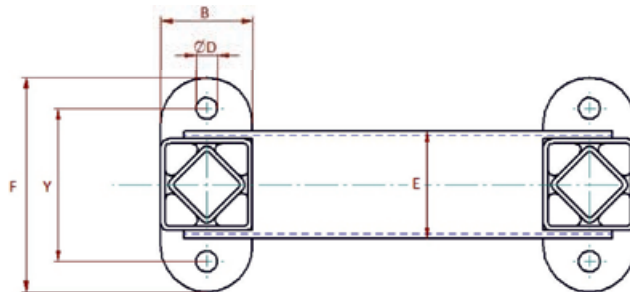
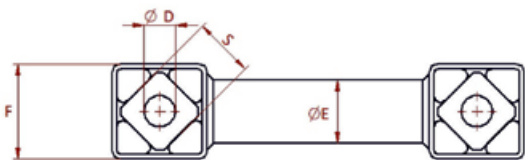

Abmasse/Material/dimensions/material

Typ type	Art. Nr. art. no.	max. Last max. load	Cd	A	C	øD	E	F	H	W	S	Gewicht weight	Material	
		N	N/mm									kg	Gehäuse housing	Innenteil core
DB-C 5 – 60 160	100 010 56	420	12	160	34	16	34	50	65	209	27	2.3	Stahl mit Pulverlackierung steel with powder coating	Aluminium
DB-C 6 – 80 200	100 010 68	840	20	200	40	20	40	60	90	260	38	2.9		

Abmasse/Material/dimensions/material

Typ type	Art. Nr. art. no.	max. Last max. load	Cd	A	B	C	øD	E	F	H	Y	Gewicht weight	Material	
		N	N/mm									kg	Gehäuse housing	Innenteil core
DB-F 3 – 40 100	100 011 34	120	5	100	25	16	7	16	70	48	50	0.4	Stahl mit Pulverlackierung steel with powder coating	
DB-F 4 – 50 120	100 011 45	220	11	120	30	24	8	24	82	61	60	0.7		
DB-F 5 – 60 160	100 011 56	420	12	160	45	34	11	34	110	73	80	1.5		
DB-F 6 – 80 200	100 011 68	820	20	200	60	70	14	50	140	95	100	3.5		
DB-F 7 – 100 200	100 011 71	1 620	34	200	70	47	18	47	180	120	130	5.6		
DB-F 8 – 120 250	100 011 82	2 520	39	250	80	60	18	60	190	145	140	8.3		

Abmasse/Material/dimensions/material

Typ type	Art. Nr. art. no.	max. Last max. load	Cd	A	B	C	D	E	F	H	H1	Y	Gewicht weight	Material	
		N	N/mm										kg	Gehäuse housing	Innenteil core
DB-FM 3 – 40 100	100 012 34	120	5	100	25	16	7	16	70	48	53	50	0.4	Stahl mit Pulverlackierung steel with powder coating	
DB-FM 4 – 50 120	100 012 45	220	11	120	30	24	8	24	82	61	65	60	0.7		
DB-FM 5 – 60 160	100 012 56	420	12	160	45	34	11	34	110	73	79	80	1.5		
DB-FM 6 – 80 200	100 012 68	820	20	200	60	70	14	50	140	95	95	100	3.5		
DB-FM 7 – 100 200	100 012 71	1 620	34	200	70	47	18	47	180	120	131	130	5.6		
DB-FM 8 – 120 250	100 012 82	2 520	39	250	80	60	18	60	190	145	155	140	8.3		

Cd = dynamische Federrate bei Schwingwinkeln von $\pm 5^\circ$ und Geschwindigkeiten von 300–600 min⁻¹
weitere Größen auf Anfrage

Cd = dynamic spring value by oscillating angles of $\pm 5^\circ$ at speed ranges of 300–600 rpm.
other dimensions on request

DOPPELSCHWINGEN TYP TB-C/TB-F/TB-FM

DOUBLE ROCKER TB-C/TB-F/TB-FM

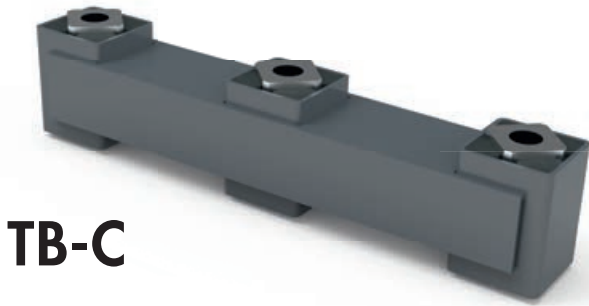

TB-C

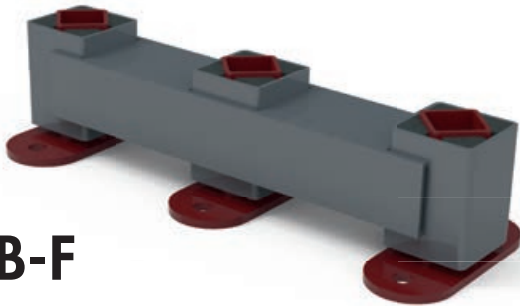

TB-F

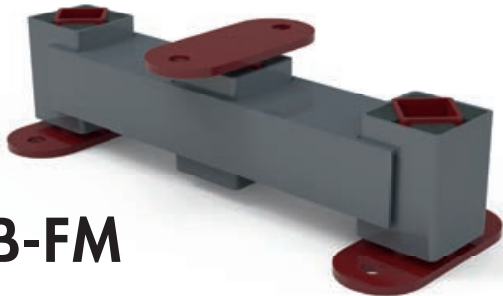

TB-FM

RESATEC DOPPELSCHWINGEN TYP TB-C/TB-F/TB-FM

Die RESATEC Doppelschwinge Typ TB wird in kurbelwellengetriebenen Förder-, Sieb-, Sortieranlagen etc. als geführtes Zweimassensystem zur Rinnenabstützung eingesetzt. Die Doppelschwingen haben normierte Achsabstände und sind für Schwingwinkel bis max. $\pm 6^\circ$ einsetzbar. Ideale Werte werden bei gleicher Masse der beiden Siebdecks erreicht. Der Abstand zwischen den einzelnen Schwingen soll 1,5 m nicht überschreiten. Der Typ C ist für Zentralbefestigung und die Typen F und FM für Flanscbefestigung ausgelegt. Kunden-spezifische Ausführungen, auch mit asymmetrischen Achsabständen, sind möglich.

RESATEC DOUBLE ROCKER TYPE TB-C/TB-F/TB-FM

The RESATEC double rocker type TB is used in crankshaft driven conveying, screening, sorting plants etc. as a guided two mass system for trough support. The double rocker arms have standardized center distances and can be used for oscillation angles up to max. $\pm 6^\circ$. Ideal values are achieved when the two screen decks have the same mass. The distance between the individual swings should not exceed 1.5 m. Type C is designed for central mounting and types F and FM for flange mounting. Customer-specific designs, also with asymmetrical center distances, are possible.

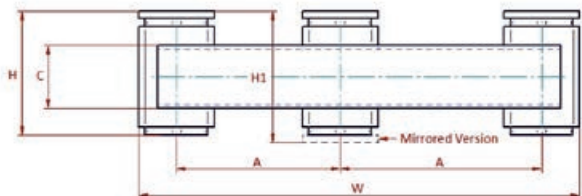
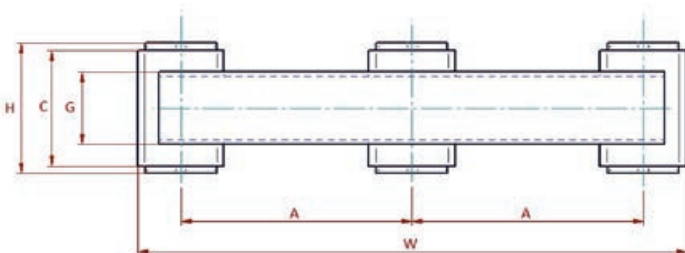
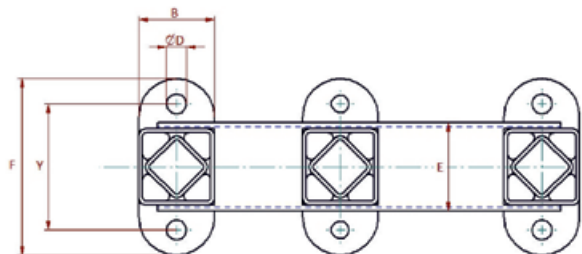
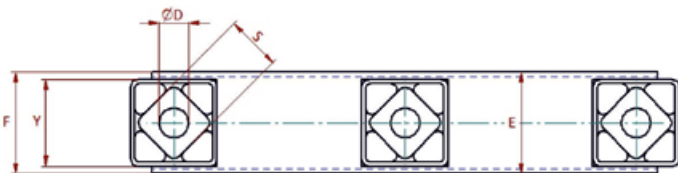

Abmasse/Material/dimensions/material

Typ type	Art. Nr. art. no.	max. Last max. load	Cd	A	C	øD	E	F	G	H	W	S	Gewicht weight	Material	
		N	N/mm										kg	Gehäuse housing	Innenteil core
TB-C 5 – 60 120	100 013 56	320	32	120	60	16	50	50	50	65	365	27	2.7	Stahl mit Pulverlackierung steel with powder coating	Aluminium
TB-C 6 – 80 160	100 013 68	620	48	160	80	20	70	70	50	90	380	38	3.4		

Abmasse/Material/dimensions/material

Typ type	Art. Nr. art. no.	max. Last max. load	Cd	A	B	C	øD	E	F	H	Y	Gewicht weight	Material	
		N	N/mm									kg	Gehäuse housing	Innenteil core
TB-F 3 – 40 100	100 014 34	75	12	100	25	16	7	16	70	48	50	1.2	Stahl mit Pulverlackierung steel with powder coating	
TB-F 4 – 50 100	100 014 45	160	23	100	30	40	9	36	82	61	60	1.5		
TB-F 5 – 60 120	100 014 56	310	32	120	45	50	11	50	110	73	80	2.5		
TB-F 6 – 80 160	100 014 68	610	48	160	60	70	14	50	140	86	100	5		
TB-F 7 – 100 200	100 014 71	1 210	52	200	70	90	18	50	170	120	130	9.8		
TB-F 8 – 120 250	100 014 82	1 810	59	250	80	60	18	60	190	145	140	12.9		

Abmasse/Material/dimensions/material

Typ type	Art. Nr. art. no.	max. Last max. load	Cd	A	B	C	D	E	F	H	HI	Y	Gewicht weight	max. Belastung max. Belastung	Material	
		N	N/mm										kg	N	Gehäuse housing	Innenteil core
TB-FM 3 – 40 100	100 015 34	75	12	100	25	18	7	18	70	50	56	50	1.2	75	Stahl mit Pulverlackierung steel with powder coating	
TB-FM 4 – 50 100	100 015 45	160	23	100	30	40	9	36	82	61	68	60	1.5	160		
TB-FM 5 – 60 120	100 015 56	310	32	120	45	50	11	50	110	73	79	80	2.5	310		
TB-FM 6 – 80 160	100 015 68	610	48	160	60	70	14	50	140	86	104	100	5	610		
TB-FM 7 – 100 200	100 015 71	1 210	52	200	70	50	18	90	170	120	131	130	9.8	1 210		
TB-FM 8 – 120 250	100 015 82	1 810	59	250	80	60	18	60	190	145	155	140	12.9	1 810		

Cd = dynamische Federrate bei Schwingwinkeln von $\pm 5^\circ$ und Geschwindigkeiten von $300-600 \text{ min}^{-1}$
weitere Größen auf Anfrage

Cd = dynamic spring value by oscillating angles of $\pm 5^\circ$ at speed ranges of $300-600 \text{ rpm}$.
other dimensions on request

SCHWINGUNGSDÄMPFER

VIBRATION ABSORBER

VD

G1/GN1

G2/GN2

K1/KN1

K2/KN2

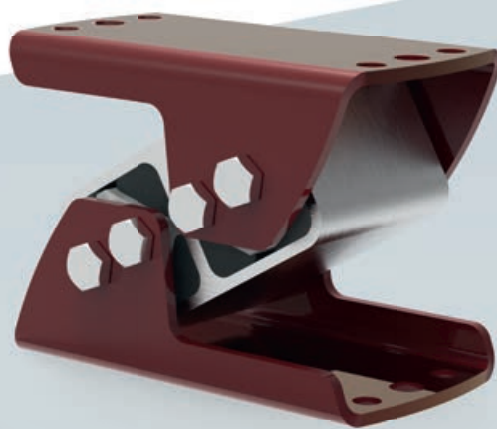

VD



**G2
GN2**



**G1
GN1**



**K2
KN2**



**K1
KN1**

SCHWINGUNGSDÄMPFER TYP VD

VIBRATION ABSORBER TYPE VD



RESATEC SCHWINGUNGSDÄMPFER TYP VD:

Die RESATEC Schwingungsdämpfer Typ VD sind vorwiegend für die überkritische Isolation geeignet. Der grosse Federweg ergibt eine weiche Lagerung und somit eine kleine Eigenfrequenz. Die Erregerfrequenz kann amplitudenabhängig bis 50Hz betragen. Das Frequenzverhältnis von der Eigenfrequenz zur Erregerfrequenz soll mindestens 1:1,4 sein. Der Schwingungsdämpfer kann auf Zug, Druck und Schub belastet werden.

RESATEC VIBRATION ABSORBER MOUNTS TYPE VD:

RESATEC vibration absorber mounts type VD are mainly suitable for supercritical isolation. The large spring travel results in a soft bearing and thus a small natural frequency. The excitation frequency can be up to 50Hz depending on the amplitude. The frequency ratio of the natural frequency to the excitation frequency should be at least 1:1.4. The vibration damper can be loaded in tensile, pressure and shear.

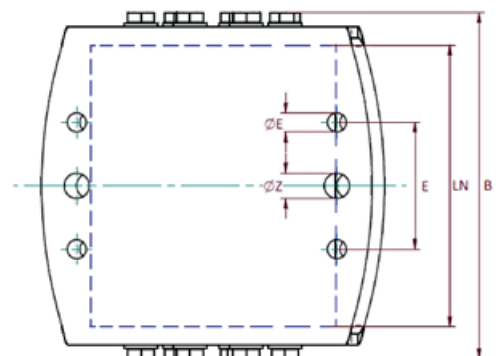
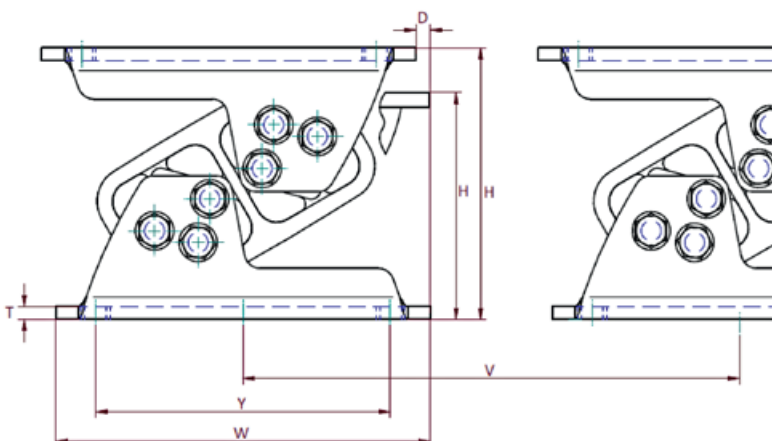
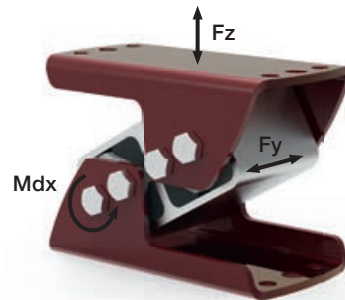

Abmasse/Material/dimensions/material

Typ type	Art. Nr. art. no.	H		D		W	B	LN	T	E	øE +/- 0.2	øZ +/- 0.2	Y	V	Gewicht weight
		unbelastet unloaded	max. Last max. load	unbelastet unloaded	max. Last max. load										
VD 5 – 60	581 005 02	97	83 – 79	1.6	–3.7 bis –4.1	150	84	60	4	40	9	11	120	185	1.4
VD 6 – 80	581 006 02	128.5	108 – 104	1.25	–6.0 bis –6.5	176	126	80	5	50	11	13.5	150	210	3.6
VD 7 – 110	581 007 02	162	138 – 134	22.5	14 – 12	220	158	110	6	80	13.5	18	170	255	6.6
VD 8 – 120	581 008 01	170	138 – 135	9	2 – 0	235	179	120	6	90	13	18	185	260	8.5
VD 8 – 200	581 008 03	170	138 – 135	9	2 – 0	235	259	200	6	90	13	18	185	260	14.1

Material

Gehäuse: Aluminium
 Innenprofil: Aluminium
 Support: Stahl mit Pulverlackierung

Material

housing: Aluminium
 core profile: Aluminium
 support: steel with powder coating

Belastungswerte/load values, max. Einsatzparameter/capacity limits

Typ type	Art. Nr. art. no.	Belastung/load				Eigenfrequenz fe/ natural frequency fe		kinetische Energieaufnahme kinetic energy absorption
		Fz		Mdx	Fy	min. Fz	max. Fz	
		min. N	max. N	max. Md N	max. Nm	Hz	Hz	
VD 5 – 60	581 005 02	700	2 000	69	325	6.8	4.6	96
VD 6 – 80	581 006 02	1 200	3 800	170	515	5.9	3.9	240
VD 7 – 110	581 007 02	2 200	6 100	350	735	5.2	3.6	490
VD 8 – 120	581 008 01	3 500	11 000	570	865	4.5	3.8	790
VD 8 – 200	581 008 03	6 300	19 000	950	1 080	4.5	3.8	1 320

SCHWINGUNGSDÄMPFER TYP G1/GN1 G2/GN2

VIBRATION ABSORBER TYPE G1/GN1 G2/GN2



G1/GN1



G2/GN2

RESATEC SCHWINGUNGSDÄMPFER TYP G1/GN1 UND G2/GN2

Der RESATEC Schwingungsdämpfer Typ G1/GN1 beziehungsweise G2/GN2 besteht aus einem Aluminium-Gussdeckel und

G1/GN1: Einer aufgeleimten blauen Sylomer-Dämpfplatte und ist vorwiegend zur Lagerung von Ventilatoren, Klimageräten, Haushaltsmaschinen, Handling-Geräte, Transportanlagen, Pumpen, kleine Kompressoren und Flüssigkeitstanks als Körperschall-Isolation und als Aktiv-Isolation geeignet.

G2/GN2: Einer öl- und benzinbeständigen aufgeleimten schwarzen NBR-Dämpfplatte mit erhöhter Lagerungsstabilität zur Lagerung von leichten Werkzeugmaschinen, Montageautomaten, Geräte in Garagen und Anlagen in Produktionsstrassen als Körperschall-Isolation und als Aktiv-Isolation geeignet.

Der Gussdeckel kann in der Variante G1/G2 direkt auf Druck belastet werden. In der Variante GN1/GN2 ist eine frei drehbare Schraube zur stufenlosen Nivellierung vorhanden. Bodenunebenheiten können bis zu $\pm 5^\circ$ kompensiert werden.

RESATEC VIBRATION ABSORBER TYPE G1/GN1 AND G2/GN2

The RESATEC vibration absorber type G1/GN1 respectively G2/GN2 consists of an aluminum cast cover and

G1/GN1: A glued-on blue Sylomer cushioning plate and is mainly suitable for the mounting of fans, air conditioners, household machines, handling equipment, transport systems, pumps, small compressors and liquid tanks as isolation of structure-borne noise and vibrations.

G2/GN2: An oil and gasoline resistant glued-on black NBR cushioning plate with increased bearing stability suitable for the mounting of light tool machines, automatic assembly machines, equipment in garages and equipment in production lines as isolation of structure-borne noise and vibrations.

In the G1/G2 variant, the cast cover can be loaded directly under pressure. In the GN1/GN2 version, there is a screw for levelling. Uneven surfaces can be compensated for up to $\pm 5^\circ$.

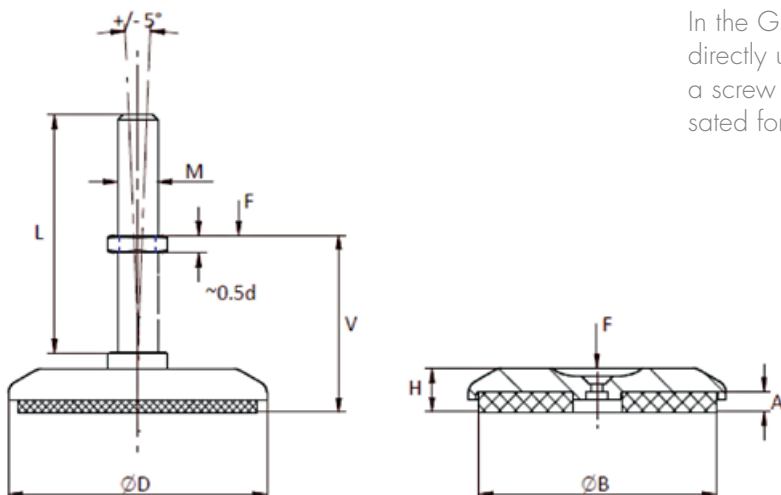

Abmasse, Belastungswerte und Material/dimensions, load values and material

Typ type	Art. Nr. art. no.	Last load	Eigenfrequenz fe natural frequency fe	Last load	øD	M	L	V	H	A	B	Gewicht weight
		Fstat dN (kg)	Fstat Hz	Fdyn g								kg
G1 – 80	250 100 80	50 – 250	26 – 15	1.75	80	–	–	–	18	10	~70	0.13
G1 – 130	250 101 30	150 – 800	26 – 15	1.75	130	–	–	–	22	10	~120	0.47
GN1 – 80 M12×80	251 100 80	50 – 250	26 – 15	1.75	80	M12	80	32 – 90	18	10	~70	0.21
GN1 – 80 M16×120	251 100 81	50 – 250	26 – 15	1.75	80	M16	120	38 – 129	18	10	~70	0.35
GN1 – 130 M20×120	251 101 30	150 – 800	26 – 15	1.75	130	M20	120	45 – 129	22	10	~120	0.81

Abmasse, Belastungswerte und Material/dimensions, load values and material

Typ type	Art. Nr. art. no.	Last load	Eigenfrequenz fe natural frequency fe	Last load	øD	M	L	V	H	A	B	Gewicht weight
		Fstat dN (kg)	Fstat Hz	Fdyn g								kg
G2 – 80	250 200 80	200 – 800	20 – 16	1.75	80	–	–	–	16.5	8	~70	0.13
G2 – 130	250 201 30	600 – 2 200	21 – 15	1.75	130	–	–	–	20	8	~120	0.48
GN2 – 80 M12×80	251 200 80	200 – 800	20 – 16	1.75	80	M12	80	30 – 88	16.5	8	~70	0.22
GN2 – 80 M16×120	251 200 81	200 – 800	20 – 16	1.75	80	M16	120	36 – 127	16.5	8	~70	0.35
GN2 – 130 M20×120	251 201 30	600 – 2 200	21 – 15	1.75	130	M20	120	43 – 127	20	8	~120	0.84

Material

G1/GN1: blaues Dämpfungskissen aus Sylomer®/Elastomer auf PUR-Basis
Temperaturbereich – 30°C bis 70°C
G2/GN2: schwarzes Dämpfungskissen aus NBR
Temperaturbereich – 25°C bis 70°C
Gussdeckel aus EN-AC-47000,
Schraube DIN 933 ISO 4017 Stahl 8,8 galvanisch verzinkt
ökt/Mutter DIN 439 B ISO 4035 Stahl 8,8 galvanisch verzinkt

Material

G1/GN1: blue resilient pad made in Sylomer®/elastomer PUR-based
temperatur range – 30° until 70°C
G2/GN2: black resilient pad made in NBR
temperatur range – 25°C until 70°C
top cast cover made EN-AC-47000
screw DIN 933 ISO 4017 steel 8.8 galvanised
hex-nut DIN 439 ISO 4035 steel 8.8 galvanised

SCHWINGUNGSDÄMPFER TYP K1/KN1 K2/KN2

VIBRATION ABSORBER TYPE K1/KN1 K2/KN2



K1/KN1



K2/KN2

RESATEC SCHWINGUNGSDÄMPFER TYP K1/KN1 UND K2/KN2:

Der RESATEC Schwingungsdämpfer Typ K besteht aus einem Aluminium-Gussdeckel und einem aufgeleimten rostbeständigen Stahldrahtkissen. Damit ist dieser Dämpfer ölbeständig und Wärme wird ohne Stau abgeführt.

Der Typ **K1/KN1** eignet sich als Aktiv-Isolation mit hoher Stabilität für die Lagerung von Werkzeugmaschinen mit hoher Drehzahl und kleiner Schwingamplitude wie Fräsmaschinen, Drehbänke, Bohrmaschinen, Richtbänke, Schraubenkompressoren oder hydraulischen Pressen.

Der Typ **K2/KN2** ist weicher, hat somit eine kleinere Eigenfrequenz und eignet sich als Aktiv-Isolation für die Lagerung von Werkzeugmaschinen mit geringer Erregerfrequenz und grosser Bewegung wie Exzenterpressen, Kolbenkompressoren und Stanzmaschinen. Als Passiv-Isolation eignet sich der Typ K2/KN2 für die Lagerung von Läppmaschinen, Druckwalzen, Schleifmaschinen, Transformatoren und als Fundamentlagerung.

In der Variante **KN1/KN2** ist eine Schraube zur stufenlosen Nivellierung vorhanden. Bodenunebenheiten können bis zu $\pm 5^\circ$ kompensiert werden.

RESATEC VIBRATION ABSORBER TYPE K1/KN1 AND K2/KN2:

The RESATEC vibration absorber type K consists of a cast aluminum cover and a glued-on rust-resistant steel wire cushion. As a result, this absorber is oil resistant and heat is dissipated without accumulation. Type **K1/KN1** is suitable as active isolation with high stability for the mounting of tool machines with high speed and small vibration amplitude such as milling machines, lathes, drilling machines, straightening benches, screw compressors or hydraulic presses.

Type **K2/KN2** is softer, thus has a lower natural frequency and is suitable as active isolation for the mounting of machine tools with low excitation frequency and large process motion such as eccentric presses, piston compressors and punching machines. As passive insulation, type K2/KN2 is suitable for the mounting of lapping machines, printing rollers, grinding machines, transformers and as foundation mounting.

In the **KN1/KN2** variant, a screw is provided for leveling. Uneven surfaces can be compensated up to $\pm 5^\circ$.

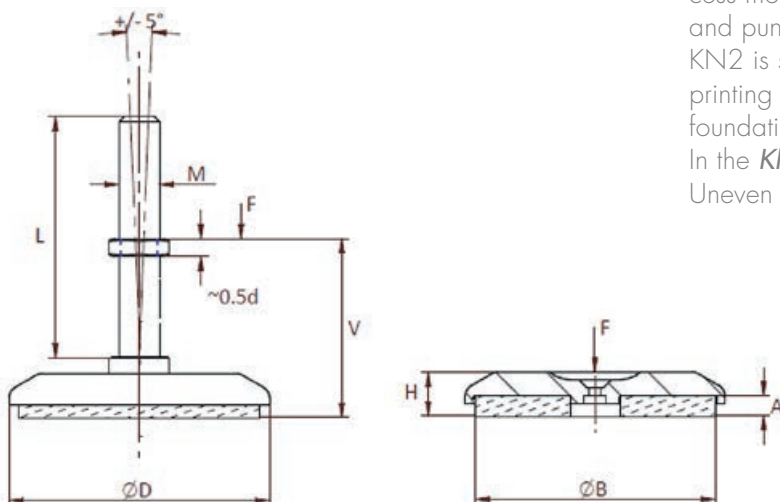

Abmasse, Belastungswerte und Material/dimensions, load values and material

Typ type	Art. Nr. art. no.	Last load	Eigenfrequenz fe natural frequency fe	Last load	øD	M	L	V	H	A	B	Gewicht weight
		Fstat dN (kg)	Fstat Hz	Fdyn g								kg
K1 – 80	250 300 80	100 – 1 300	24 – 20	2.1	80	–	–	–	19	10	~70	0.19
K1 – 130	250 301 30	400 – 2 700	21 – 18	2.1	130	–	–	–	23	10	~120	0.65
K1 – 170	250 301 70	1500 – 7 000	35 – 28	2.1	170	–	–	–	30	10	~155	3.3
KN1 – 80 M16×120	251 300 80	100 – 1 300	24 – 20	2.1	80	M16	120	35 – 125	19	10	~70	0.4
KN1 – 130 M20×120	251 301 30	400 – 2 700	21 – 18	2.1	130	M20	120	45 – 130	23	10	~120	1

Abmasse, Belastungswerte und Material/dimensions, load values and material

Typ type	Art. Nr. art. no.	Last load	Eigenfrequenz fe natural frequency fe	Last load	øD	M	L	V	H	A	B	Gewicht weight
		Fstat dN (kg)	Fstat Hz	Fdyn g								kg
K2 – 80	250 400 80	100 – 1300	14 – 12	2.1	80	–	–	–	27	19	~70	0.27
K2 – 130	250 401 30	400 – 2700	14 – 12	2.1	130	–	–	–	31	18	~120	0.92
K2 – 170	250 401 70	1500 – 7000	22 – 20	2.1	170	–	–	–	41	20	~155	3.72
KN2 – 80 M16×120	251 400 80	100 – 1300	14 – 12	2.1	80	M16	120	45 – 140	27	19	~70	0.48
KN2 – 130 M20×120	251 401 30	400 – 2700	14 – 12	2.1	130	M20	120	50 – 140	31	18	~120	1.30

Material

Dämpfungskissen aus gestricktem und gepresstem CR-Ni Stahldraht
 Temperaturbereich –25 °C bis 300 °C
 Gussdeckel K-80 und K-130 aus EN-AC-47000
 Schraube DIN 933 ISO 4017 Stahl 8,8 galvanisch verzinkt
 6kt-Mutter DIN 439 B ISO 4035 Stahl 8,8 galvanisch verzinkt

Material

resilient pad made in knitted and pressed chromium-nickel steel wire
 temperatur range –25 °C until 300 °C
 top cast cover K-80 and K-130 made in EN-AC-47000
 top cast cover K170 made in EN-GJS-400/powder coating
 screw DIN 933 ISO 4017 steel 8.8 galvanised
 hex-nut DIN 439 ISO 4035 steel 8.8 galvanised

MOTORWIPPEN

MOTOR BASES

MW-8-270/MW-8-400/MW-8-500

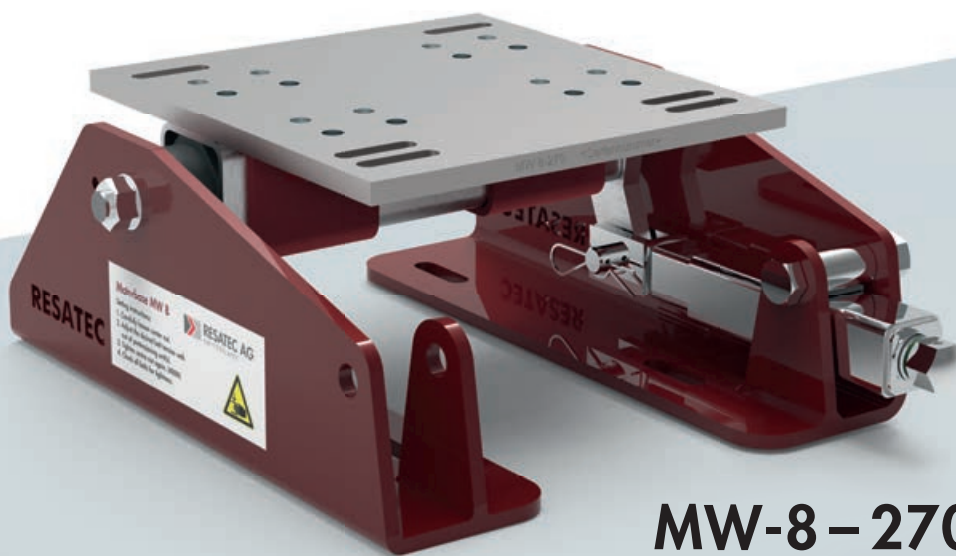

MW-8-270

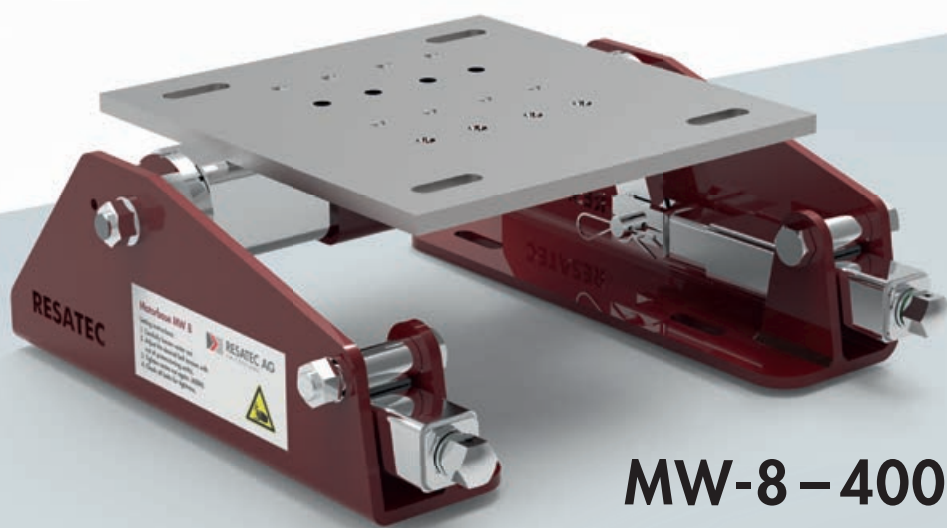

MW-8 – 400/500

MOTORWIPPE TYP MW-8

MOTOR BASE TYPE MW-8

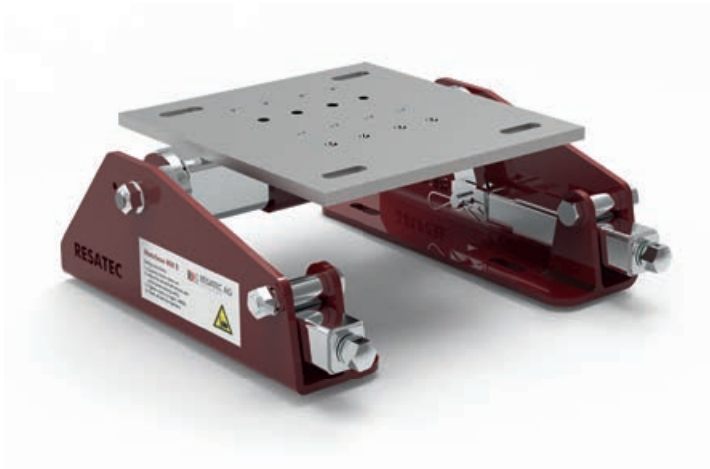

RESATEC MOTORWIPPE MW-8

Entsprechend der Riemenanzahl und des Riementyps lässt sich die Wippe stufenlos einstellen. Sie ist mit zwei integrierten Achsabstützer, robusten und wartungsfreien Vorspanneinheiten und einer Schraubkopfhalterung für eine einfache und sichere Montage ausgestattet.

Die Befestigungsbohrungen für sämtliche Motorgehäuse-Größen (IEC 160M-225M/NEMA 254T-365T) sind bereits vorhanden. Der Einsatz der RESATEC Motorwippe garantiert jederzeit die optimale Riemenspannung. Das bedeutet minimalster Wartungsaufwand sowie höchste Effizienz durch optimale Traktion.

RESATEC-MW-8 MOTOR BASE

According to the number of belts and belt type, the base can be adjusted in a continuously variable way. It is equipped with two integrated axle stabilizers, robust and maintenance-free pretensioning device and a screw head bracket for simple and safe one-man installation.

The mounting holes for all motor housing sizes (IEC 160M-225M/NEMA of 254T-365T) are already provided. The use of the RESATEC motor base guarantees the optimal belt tension at any time. This means minimum maintenance and maximum efficiency through a perfect traction.

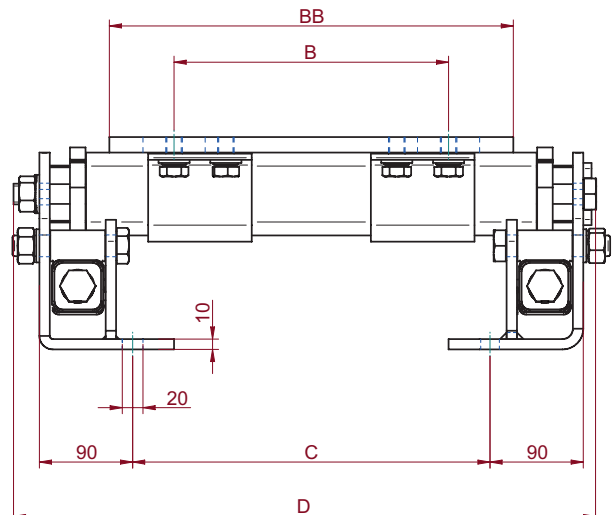
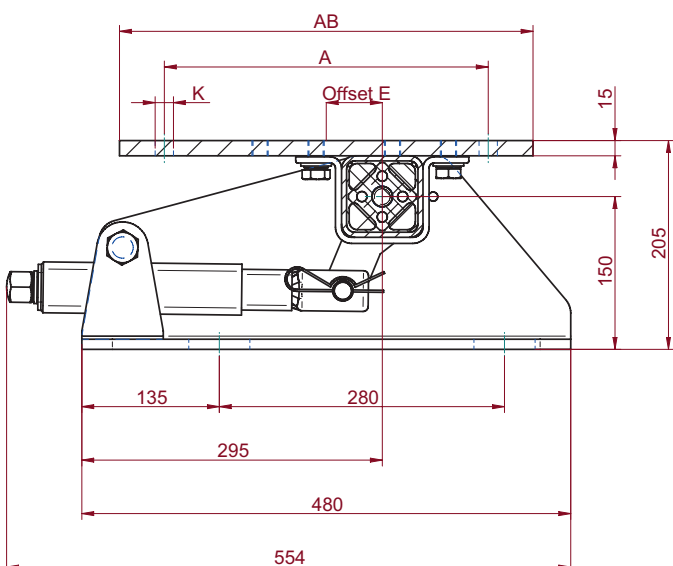

Typ type	Art. Nr. art. no.	Baugröße Motor Motor frame size	Motorenleistung (ca.) Motor power (approx.)		A	B	K	AB	BB	C	D	E	Gewicht weight
			IEC 1000 min ⁻¹ NEMA 1200 min ⁻¹	IEC 1500 min ⁻¹ NEMA 1800 min ⁻¹									
MW-8 – 270	586 082 70	IEC 160M	7.5kW	11 kW	254	210	14	335	350	245	463	38	46
		IEC 160L	11 kW	15 kW	254	254	14	335	350	245	463	38	46
		NEMA 254T	7.5 hp	15 hp	254	210	14	335	350	245	463	38	46
		NEMA 256T	10 hp	20 hp	254	254	14	335	350	245	463	38	46
		IEC 180M		18.5 kW	279	241	14	335	350	245	463	38	46
		IEC 180L	15 kW	22 kW	279	279	14	335	350	245	463	38	46
		NEMA 284T	15 hp	25 hp	279	241	14	335	350	245	463	38	46
		NEMA 286T	20 hp	30 hp	279	279	14	335	350	245	463	38	46
MW-8 – 400	586 084 00	IEC 200L	18.5/22 kW	30 kW	318	305	18	406	390	345	554	55	60
		NEMA 324T	25 hp	40 hp	318	267	18	406	390	345	554	55	60
		NEMA 326T	30 hp	50 hp	318	305	18	406	390	345	554	55	60
MW-8 – 500	586 085 00	IEC 225S		37kW	356	286	18	466	420	425	643	72	64
		IEC 225M	30 kW	45 kW	356	311	18	466	420	425	643	72	64
		NEMA 364T	40 hp	60 hp	356	286	18	466	420	425	643	72	64
		NEMA 365T	50 hp	75 hp	356	311	18	466	420	425	643	72	64

Einsatzparameter/capacity limits

Keilriemenprofil v-belt typ	Breite width	Höhe height	ød ød of smaller pulley	Prüfkraft F bei Inbetriebnahme Initial operation test force F	Prüfkraft F in Betrieb Operational test force F
	mm	mm	mm	N	N
XPZ,SPZ	10	8	56 – 71 75 – 90 95 – 125 ≥ 125	20 22 25 28	16 18 20 22
XPA, SPA	13	10	80 – 100 106 – 140 150 – 200 ≥ 200	28 38 45 50	22 30 36 40
XPB,SPB	16	13	112 – 160 170 – 224 236 – 355 ≥ 355	50 62 77 81	40 50 62 65
XPC,SPC	22	18	224 – 250 265 – 355 ≥ 375	87 115 144	70 92 115
Z	10	6	56 – 100		5 – 7.5
A	13	8	80 – 140		10 – 15
B	17	10	125 – 200		20 – 30
C	22	12	200 – 400		40 – 60
D	32	19	355 – 600		70 – 105

ANWENDUNGEN

APPLICATIONS

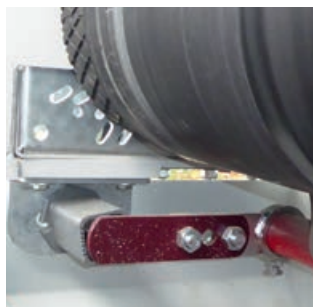
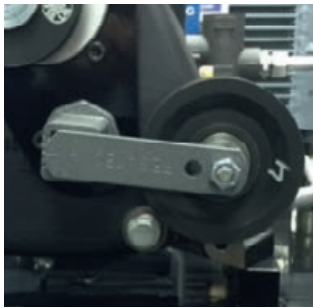



RESATEC AG
ROSENWEG 1
CH-5037 MUHEN

+41 62 723 27 24
INFO@RESATEC.CH
WWW.RESATEC.CH